

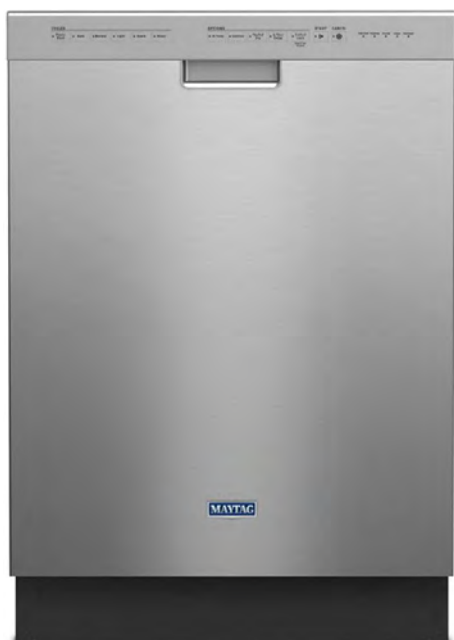

SERVICE MANUAL

**Maytag Dishwashers
4-Blade Stainless Steel Chopper**



FORWARD

This Maytag Service Manual, "Maytag Dishwashers, 4-Blade Stainless Steel Chopper" (Part No. W11035362), provides the In-Home Service Professional with service information for the "Maytag Chopper Dishwasher."

The Wiring Diagram used in this Service Manual is typical and should be used for training purposes only. Always use the Wiring Diagram supplied with the product tech sheet when servicing the dishwasher.

For specific operating and installation information on the model being serviced, refer to the "Use and Care Guide" or "Installation Instructions" provided with the dishwasher.

GOALS AND OBJECTIVES

The goal of this Service Manual is to provide information that will enable the In-Home Service Professional to properly diagnose malfunctions and repair the "Maytag Chopper Dishwasher."

The objectives of this Service Manual are to:

- Understand and follow proper safety precautions.
- Successfully troubleshoot and diagnose malfunctions.
- Successfully perform necessary repairs.
- Successfully return the dishwasher to its proper operational status.

WHIRLPOOL CORPORATION assumes no responsibility for any repairs made on our products by anyone other than authorized In-Home Service Professionals.

TABLE OF CONTENTS

Maytag Chopper Dishwashers

SECTION 1 — GENERAL INFORMATION

DISHWASHER SAFETY.....	1-2
GENERAL THEORY OF OPERATION.....	1-3
NEW COMPONENTS.....	1-4
MODEL & SERIAL NUMBER LABEL.....	1-6
TECH SHEET LOCATION.....	1-6
MODEL & SERIAL NUMBER NOMENCLATURE.....	1-7
DISHWASHER SPECIFICATIONS.....	1-8
PARTS & FEATURES.....	1-9
NOTES.....	1-10

SECTION 2 — DIAGNOSTICS & TROUBLESHOOTING

DIAGNOSTIC & TROUBLESHOOTING WARNINGS.....	2-2
SERVICE DIAGNOSTIC CYCLE.....	2-3
SERVICE DIAGNOSTIC CYCLE NOTES.....	2-4
CUSTOMER CYCLE OPERATION.....	2-4
SERVICE DIAGNOSTICS WITH ERROR CODES.....	2-5
SERVICE ERROR CODES.....	2-6
TROUBLESHOOTING GUIDE.....	2-11

SECTION 3 — TESTING

TESTING WARNINGS.....	3-2
WIRING DIAGRAM.....	3-3
CONTROL BOARD INFORMATION.....	3-4
FUSE SERVICE & RESISTANCE CHECKS.....	3-4
COMPONENT TESTING.....	3-4
ELECTRONIC CONTROL BOARD.....	3-5
METER CHECK OF LOADS & SUPPLIES.....	3-5
GENERAL THEORY OF OPERATION.....	3-6
POWER CHECK.....	3-6
DOOR SWITCH CIRCUIT.....	3-7
FILL CIRCUIT.....	3-8
DISPENSER CIRCUIT.....	3-9
WATER HEATING/HEAT DRY.....	3-10
WATER SENSING WITH OWI SENSOR.....	3-11
WASH/RINSE MOTOR.....	3-12
DRAIN MOTOR.....	3-13
VENT WAX MOTOR.....	3-14
VENT FAN.....	3-15
AC FAN MOTOR.....	3-16
POWER BLAST.....	3-17
USER INTERFACE (UI).....	3-19

TABLE OF CONTENTS (CONTINUED)

Maytag Chopper Dishwashers

SECTION 4 — COMPONENT ACCESS

ADJUSTABLE DOOR SPRINGS	4-2
INSULATION BLANKET	4-3
DOOR LATCH STRIKE.....	4-3
ACCESSING DOOR COMPONENTS.....	4-4
USER INTERFACE.....	4-4
REMOVING DOOR LATCH ASSEMBLY	4-5
REMOVING ELECTRONIC CONTROL BOARD	4-6
REMOVING DISPENSER ASSEMBLY	4-7
REMOVING WATER FILL & DISPENSER COMPONENTS.....	4-8
ADVANCED POWER DRY (SIDE DRY)	4-9
OVERFILL ASSEMBLY	4-10
IN TUB COMPONENTS.....	4-11
SPRAY ARMS, FEED TUBE, AND MANIFOLD.....	4-12
REMOVING THE RACKS	4-13
REMOVING LOWER SPRAY ARM	4-14
UNDER TUB COMPONENTS.....	4-15
REMOVING HEATER ASSEMBLY.....	4-16
REMOVING DRAIN PUMP	4-17
REMOVING OPTICAL WATER INDICATOR (OWI)	4-18
REMOVING THE SUMP ASSEMBLY	4-19
CHOPPER MOTOR ASSEMBLY PARTS	4-22
REMOVING THE CHOPPER MOTOR ASSEMBLY.....	4-23
NOTES	4-26

PRODUCT SPECIFICATIONS & WARRANTY INFORMATION SOURCES (inside back cover)

Section 1: General Information

This section provides general safety, parts, and information for the “Maytag Chopper Dishwasher.”

- Dishwasher Safety
- General Theory of Operation
- New Components
- Model & Serial Number Label
- Tech Sheet Location
- Model & Serial Number Nomenclature
- Dishwasher Specifications
- Parts & Features
- Notes

Dishwasher Safety

Your safety and the safety of others are very important.

We have provided many important safety messages in this manual and on your appliance. Always read and obey all safety messages.



This is the safety alert symbol.

This symbol alerts you to potential hazards that can kill or hurt you and others.

All safety messages will follow the safety alert symbol and either the word "DANGER" or "WARNING."

These words mean:

⚠ DANGER

You can be killed or seriously injured if you don't immediately follow instructions.

⚠ WARNING

You can be killed or seriously injured if you don't follow instructions.

All safety messages will tell you what the potential hazard is, tell you how to reduce the chance of injury, and tell you what can happen if the instructions are not followed.

General Theory of Operation

Maytag Chopper Wash System

Maintenance Free Chopper System

A 4-Blade stainless steel chopper pulverizes food, preventing particles from plugging the wash system and spray jets, providing optimal cleaning without the need to prerinse

No more scraping plates. The 4-blade stainless steel chopper disintegrates the food particles that come off your dishes so they don't end up recirculating and sticking to your dishes and glassware.

How Chopper Works (See Figure 1)

1. Water and food particles flow through the coarse filter then are disintegrated by the Chopper blades (A).
2. An impeller pulls soiled water into the wash pump through the screen (B), filtering soil particles too large to pass through and sending them back to the Chopper blades.
3. The wash water is then cycled back through the spray arms (C).
4. During the drain phase, a secondary pump flushes out used wash water.

- Maytag® dishwashers feature the most powerful motor on the market, so you can be sure what you put in comes out clean.

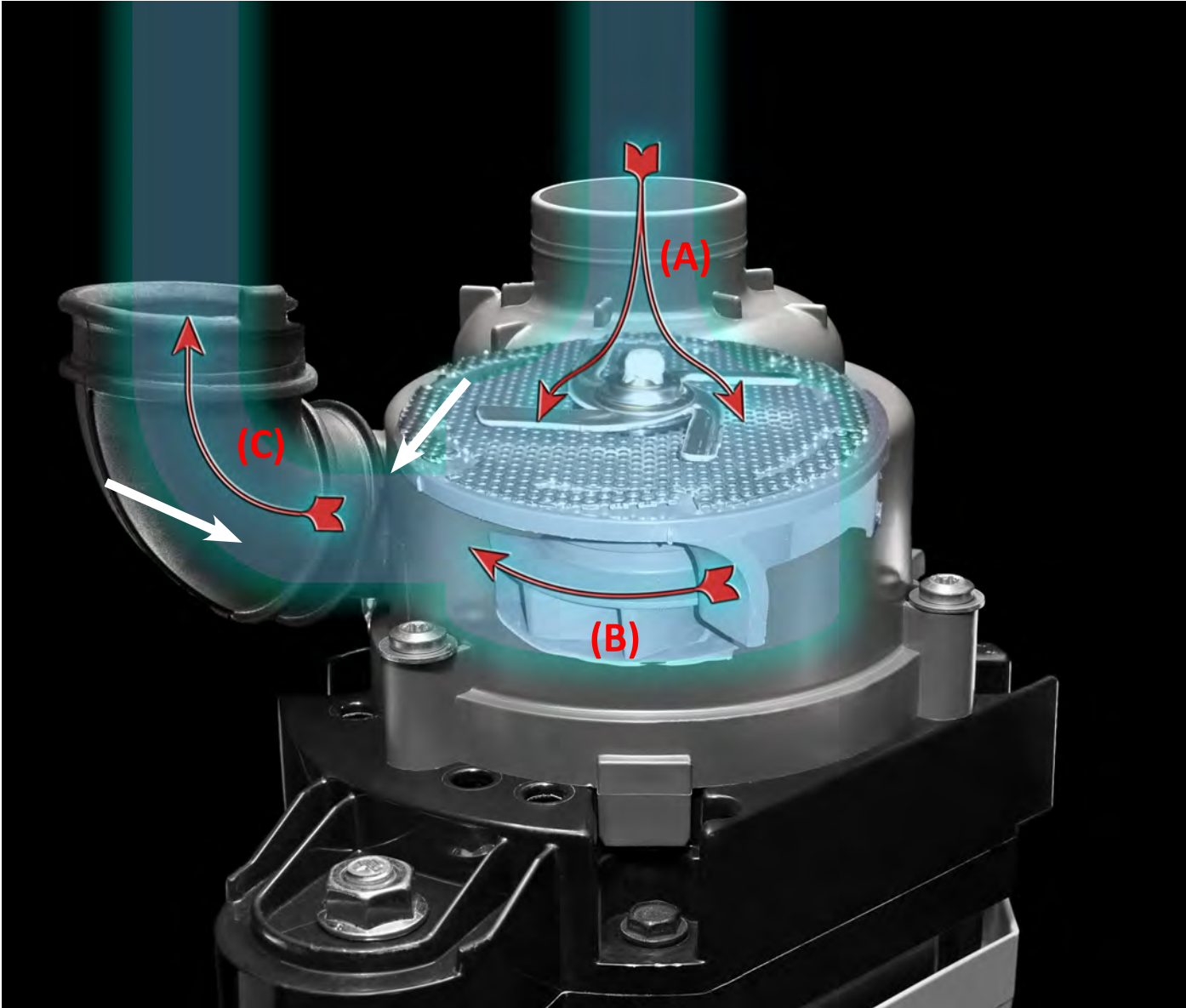

Figure 1 - Chopper Wash System

New Components

Chopper Sump Assembly Top & Bottom Views

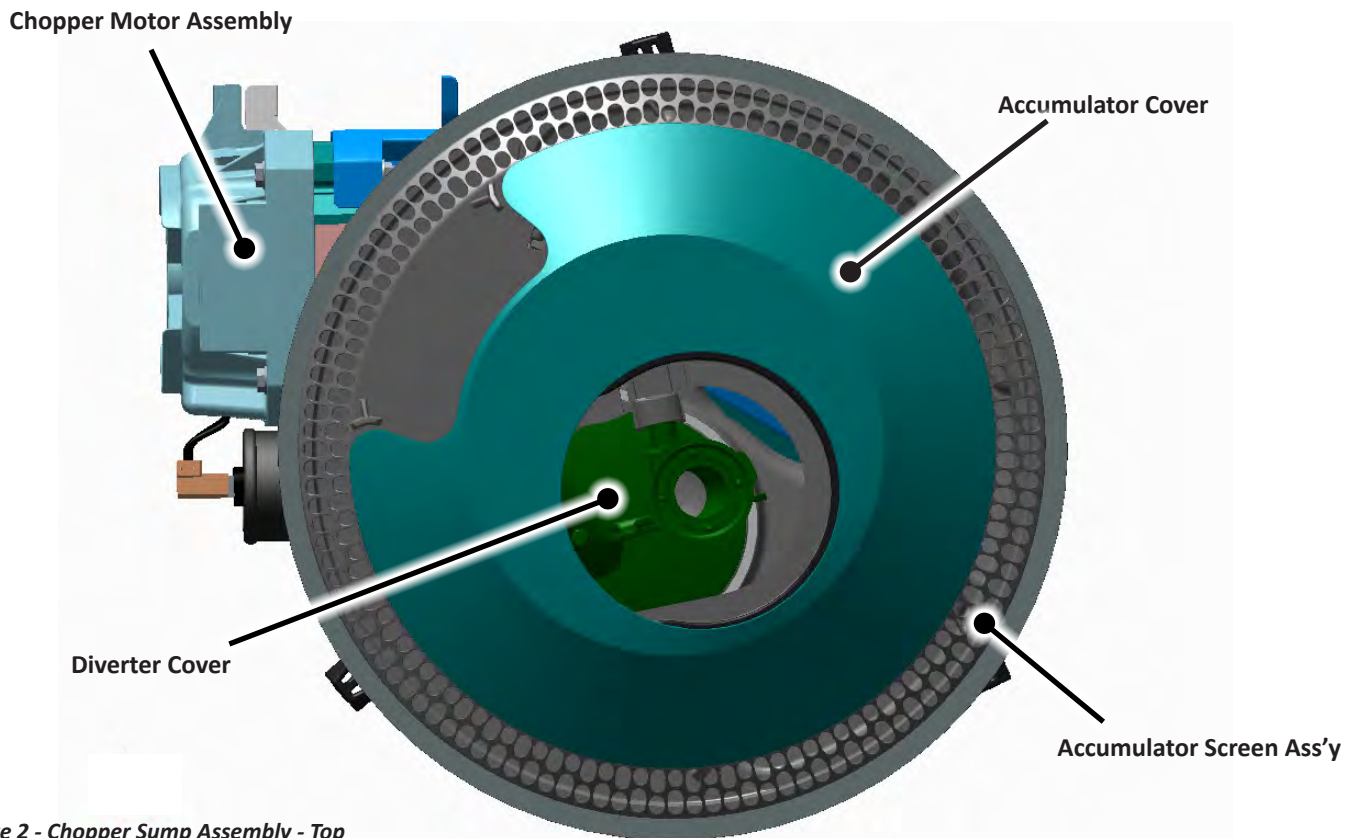

Figure 2 - Chopper Sump Assembly - Top

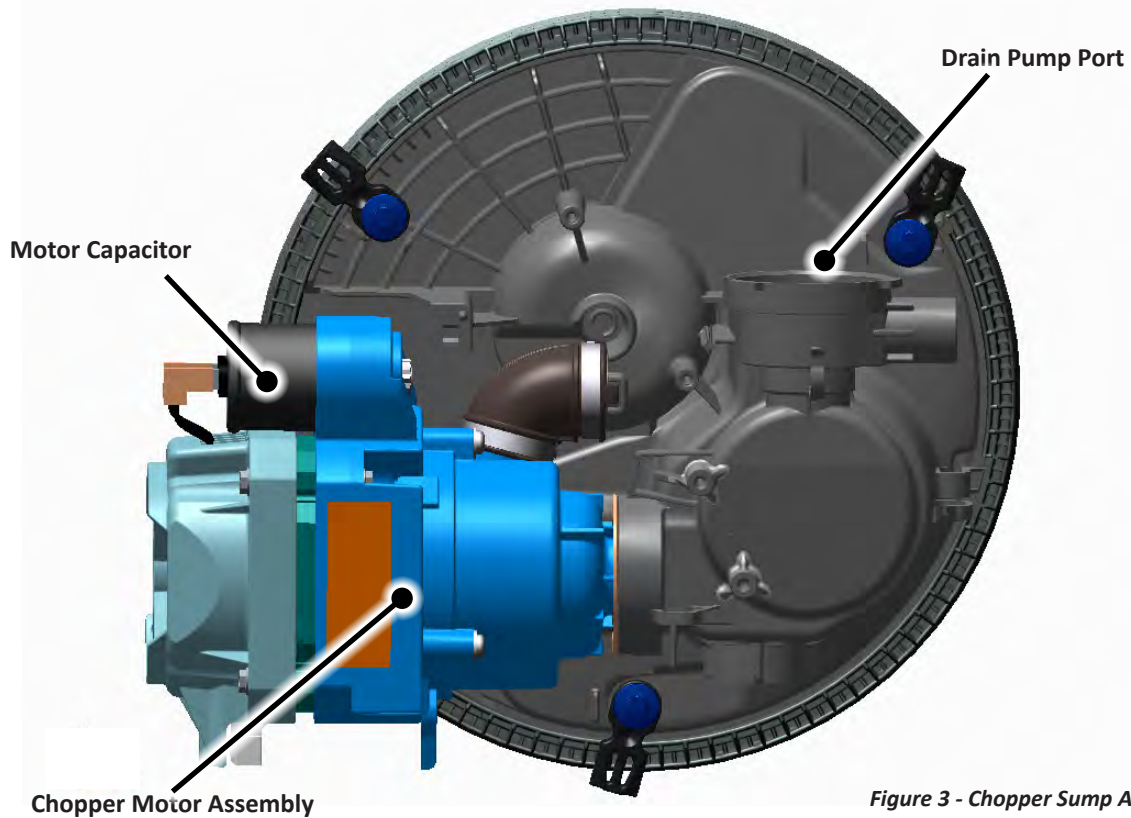

Figure 3 - Chopper Sump Assembly - Bottom

New Components

New Stainless Steel Elements



FID Console Display with Stainless Steel Bar Handle (Figure 4)



Stainless Steel Silverware Basket (Figure 5)

Full Stainless Steel Tub, Spray Arms, and Sump Cover (Figure 6)

Full Stainless Steel Tub

Stainless Steel Spray Arms

Stainless Steel Sump Cover

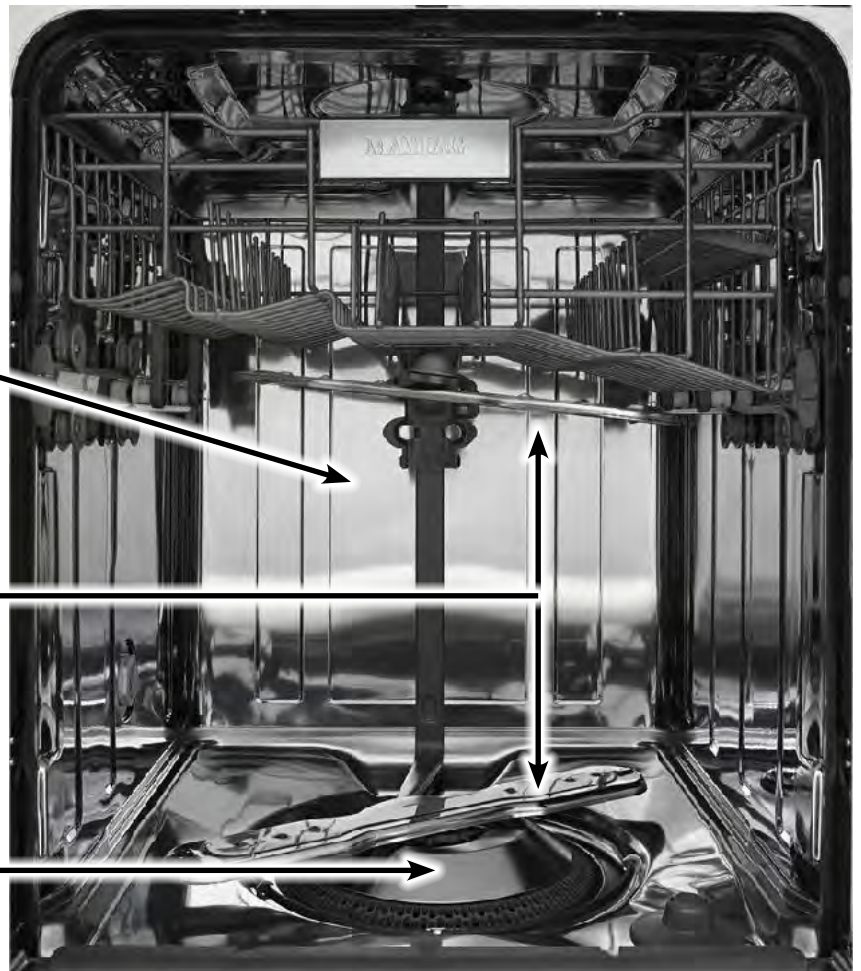

Model & Serial Number Label

Model & Serial Number Label Location



Figure 7 - Model/Serial Number Label located inside, on left side wall, toward front.

Tech Sheet Location

Tech Sheet Location



Figure 8 - Tech Sheet located behind toe panel inside insulation folds.

Model & Serial Number Nomenclature

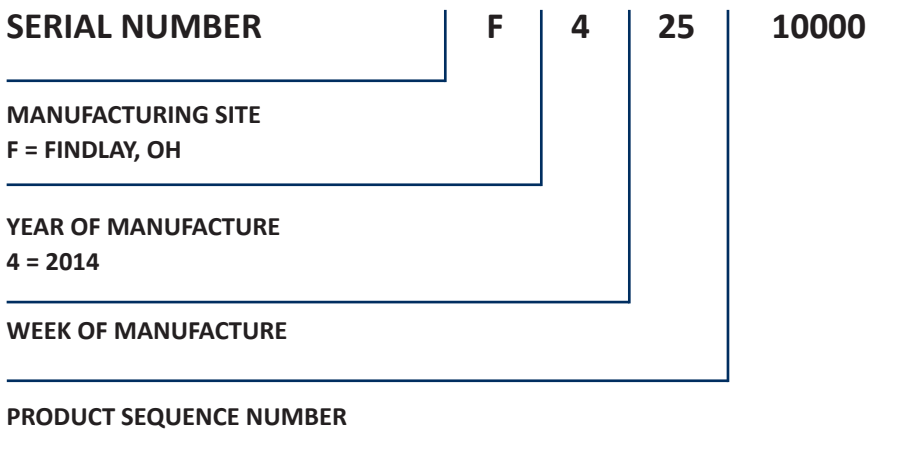
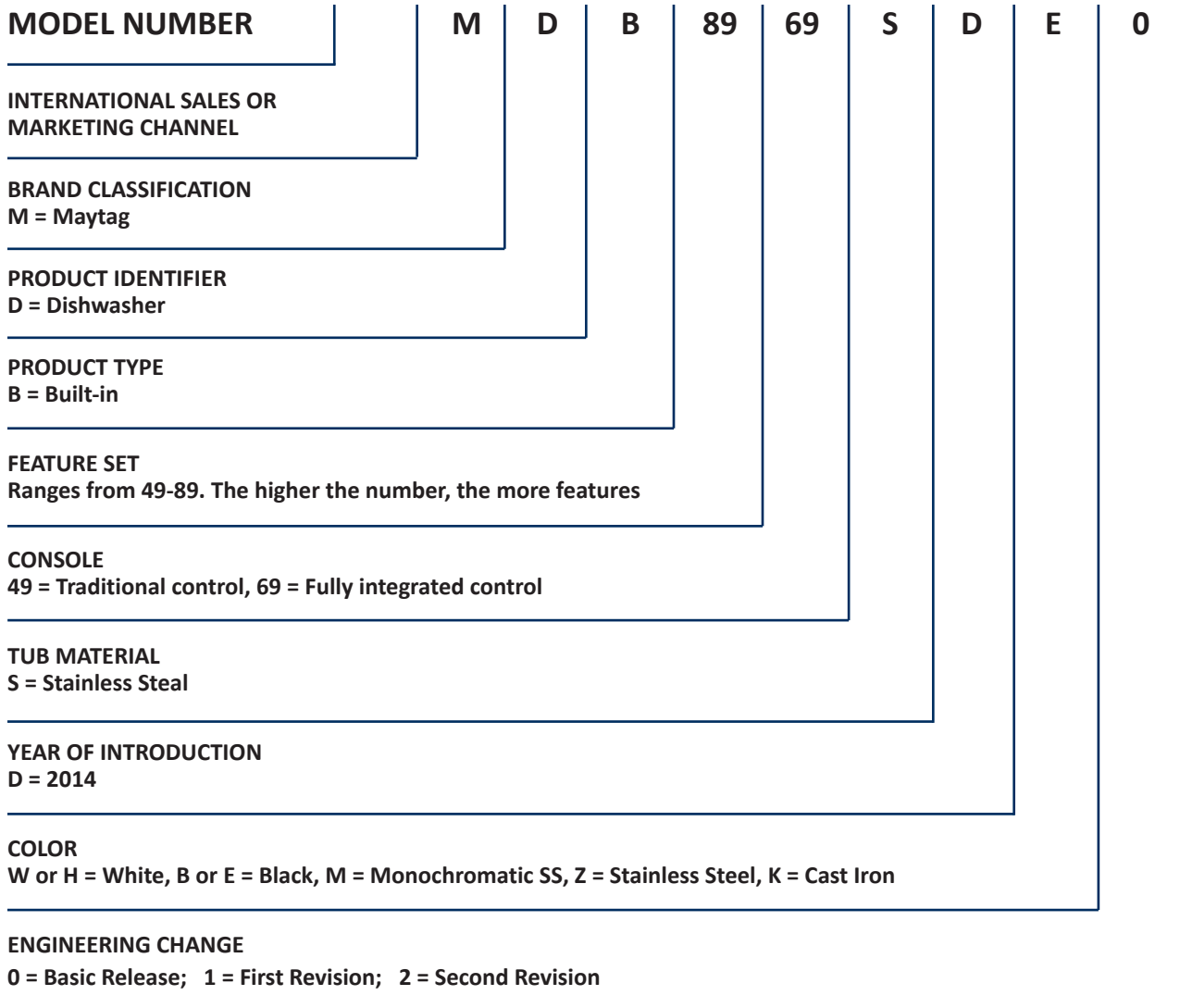

GENERAL INFORMATION

Dishwasher Specifications

Line Voltage/Frequency :	120 VAC/60 Hz
Amps :	15A
Low Volts Power Supply :	-5 VDC (REF), 13 VDC (+8V, -5V), Neutral (VCC)
Supply Water Flow Rate :	To fill 2 qt (1.9 L) in 27 seconds, 120 psi maximum, 20 psi minimum
Supply Water Temperature :	Minimum - 120° F (49° C)
Water Charge :	1.58 gal. (6.0 L) Approximate
Control :	Electronic Control
Wash Motor :	120 VAC, Run Winding (3-7 Ω), Aux Winding (6-12 Ω)
Drain Motor :	120 VAC (15-60 Ω)
Fill Valve :	120 VAC, (890-1,090 Ω)
Heater :	120 VAC, (8-30 Ω)
Dispenser :	Solenoid: 120 VAC, (260-300 Ω) Wax Motor: 120 VAC, (1.4K-3.0K Ω)
AC Fan Motor :	120 VAC, (60-80 Ω) (some models)
DC Fan Motor :	5 VDC, (31K-41K Ω)
Vent Wax Motor :	120 VAC, (600-1,800 Ω)
Power Blast Wax Motor :	120 VAC, (600-1,800 Ω)
Sensors :	NTC Thermistor Water Sensor (OWI)
Switches :	Door Switch (13 VDC) Float Switch (120 VAC)
TCO/Bi-Metal :	Incorporated into Control Board (Penninsula Slots)
Fuse :	F9 = Small Triac Load Fuse
Wash System :	Maintenance Free Hard Food Disposer
Lower Spray Arm Rotation :	12 to 40 rpm
Upper Spray Arm Rotation :	12 to 30 rpm
Filtration :	4-Blade Stainless Steel Chopper
PowerBlast	Available on all models
Depth :	24 3/4" (62.86 cm) without handles, 27 1/2" (69.85 cm) with handles
Height :	34 1/2" (87.63 cm) max., 33 1/2 (85.09 cm) min.
Width :	23 7/8" (60.64 cm)
Weight :	102 lbs. (46.27 kg)

Parts & Features

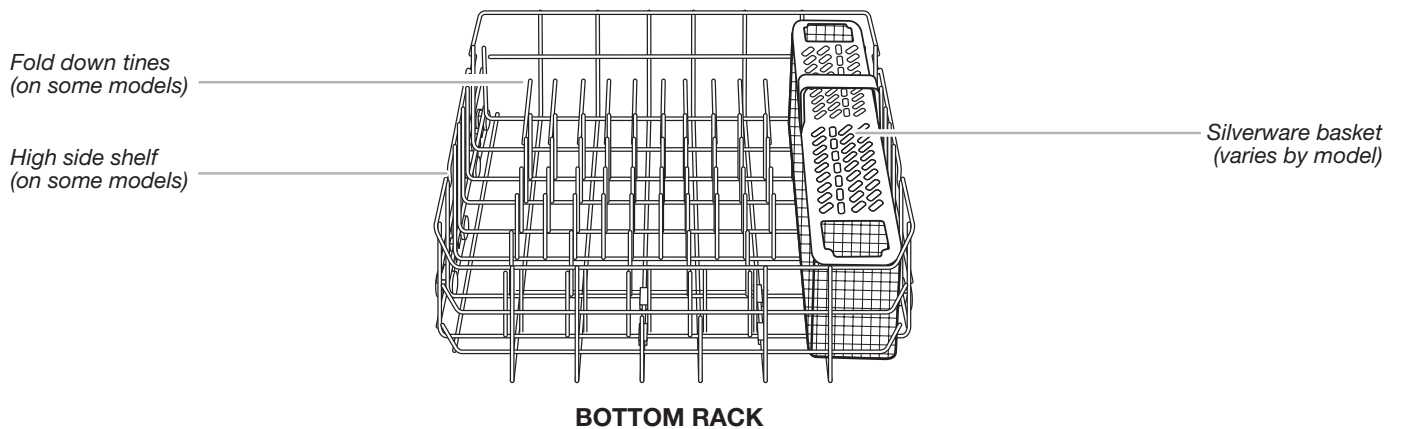
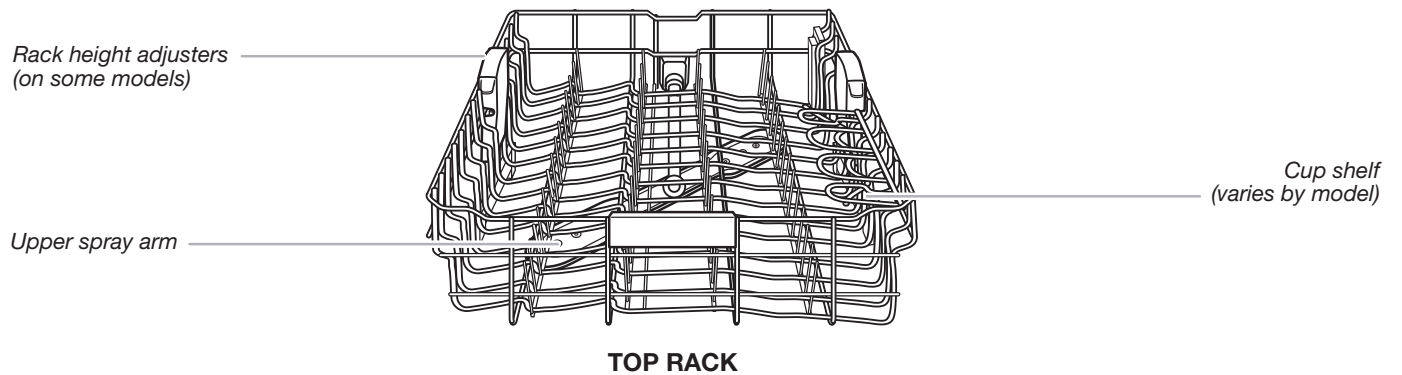
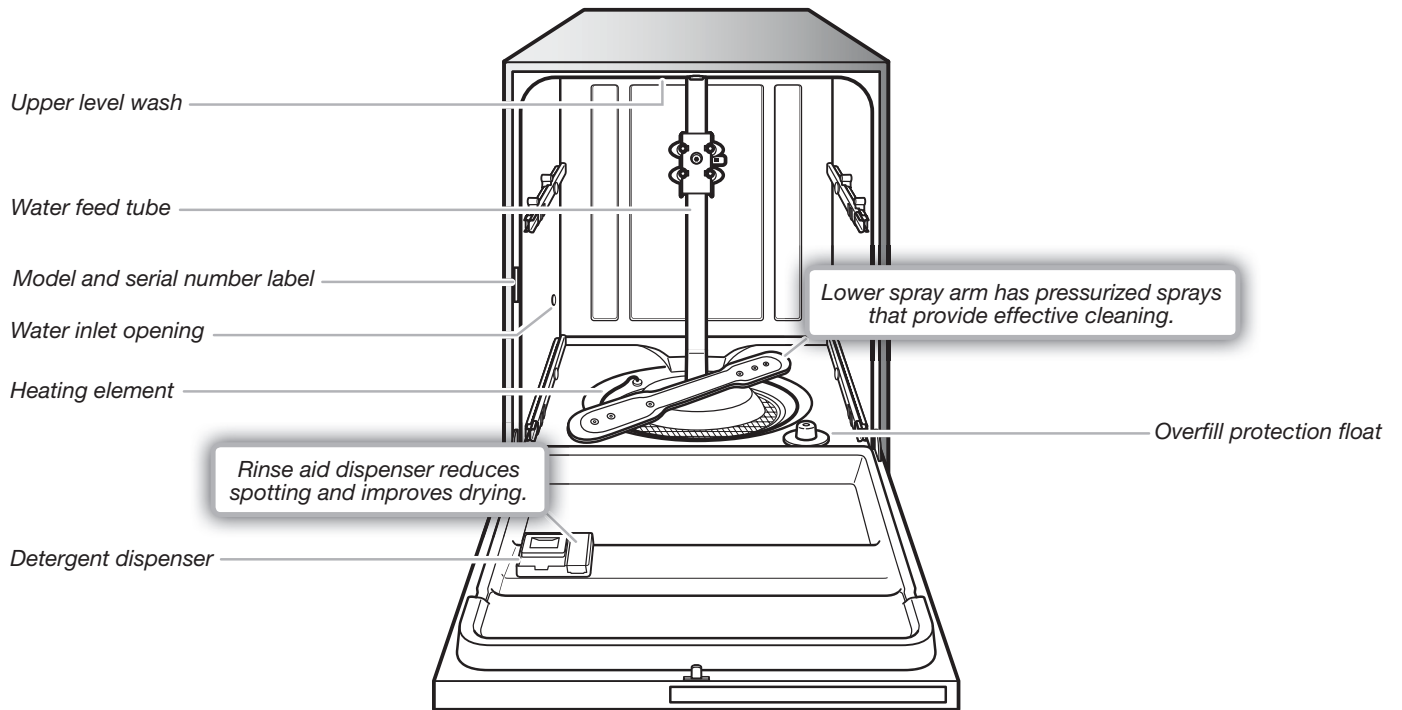

Figure 9

Notes

Section 2: Diagnostics & Troubleshooting

This section provides diagnostic, fault codes, and troubleshooting information for the “Maytag Chopper Dishwashers.”

- Diagnostics & Troubleshooting Safety
- Service Diagnostic Cycle
- Service Diagnostic Cycle Notes
- Customer Cycle Operation
- Service Diagnostics with Error Codes
- Service Error Codes
- Troubleshooting Guide

For Service Technician Use Only

⚠ DANGER



Electrical Shock Hazard

Only authorized technicians should perform diagnostic voltage measurements.

After performing voltage measurements, disconnect power before servicing.

Failure to follow these instructions can result in death or electrical shock.

⚠ WARNING



Electrical Shock Hazard

Disconnect power before servicing.

Replace all parts and panels before operating.

Failure to do so can result in death or electrical shock.

Voltage Measurement Safety Information

When performing live voltage measurements, you must do the following:

- Verify the controls are in the off position so that the appliance does not start when energized.
- Allow enough space to perform the voltage measurements without obstructions.
- Keep other people a safe distance away from the appliance to prevent potential injury.
- Always use the proper testing equipment.
- After voltage measurements, always disconnect power before servicing.

IMPORTANT: Electrostatic Discharge (ESD) Sensitive Electronics

ESD problems are present everywhere. Most people begin to feel an ESD discharge at approximately 3000V. It takes as little as 10V to destroy, damage, or weaken the main control assembly. The new main control assembly may appear to work well after repair is finished, but a malfunction may occur at a later date due to ESD stress.

- Use an anti-static wrist strap. Connect wrist strap to green ground connection point or unpainted metal in the appliance

-OR-

- Touch your finger repeatedly to a green ground connection point or unpainted metal in the appliance.
- Before removing the part from its package, touch the anti-static bag to a green ground connection point or unpainted metal in the appliance.
- Avoid touching electronic parts or terminal contacts; handle electronic control assembly by edges only.
- When repackaging main control assembly in anti-static bag, observe above instructions.

IMPORTANT SAFETY NOTICE — “For Technicians only”

This service data sheet is intended for use by persons having electrical, electronic, and mechanical experience and knowledge at a level generally considered acceptable in the appliance repair trade. Any attempt to repair a major appliance may result in personal injury and property damage. The manufacturer or seller cannot be responsible, nor assume any liability for injury or damage of any kind arising from the use of this data sheet.

For Service Technician Use Only

Service Diagnostic Cycle Notes

- 1 To invoke the Diagnostics Cycle, perform the following while in standby:
 - Press START/RESUME to wake up the control panel.
 - Press any 3 keys in the sequence 1-2-3-1-2-3-1-2-3 with no more than 1 second between key presses.
 - The Service Diagnostics Cycle will start when the door is closed.
 - To rapid advance 1 interval at a time, press START/RESUME. Rapid advancing may skip sensor checks, as some checks require 2 complete intervals.

NOTE: While in the Diagnostic Cycle, the Start/Resume feature is turned off (for example, Auto Resume after door interrupts) and the Start/Resume key becomes an interval advance key.

 - Invoking Service Diagnostics clears all status and last run information from memory and restores defaults
 - Drain and wash motors will pulsate on and off
 - Last run cycles and options are returned to default.
 - Reset OWI calibration values to the default values.
 - Forces OWI (Optical Water Indicator) calibration cycle on next customer cycle.

NOTE: Calibration cycle may add additional rinses prior to the final rinse to assure clear water and then calibrates the OWI during the fill at the beginning of the final rinse.

 - Operating state returns to standby upon completing or terminating the service diagnostics cycle.
 - Reference “Service Diagnostics with Error Codes” section for details.
-

2. Turn on all LEDs immediately upon receiving the entry sequence (even if the door is open) for 5 seconds as a display test. Turn off all LEDs for 1 second prior to reporting customer error history.
-

3. Press HI TEMP in this interval to clear customer error history. If the Hi Temp key does not respond, the control panel is in sleep mode. Open and close the door to wake up the control panel, and then press HI TEMP to clear error history.
-

4. OWI (Optical Soil Sensor) checks -
 - Check OWI sensor for the presence of water during the interval 14, and turn on the Clean LED in interval 13 if water detected.
 - Check OWI for the presence of air during drain interval 5, and turn on the clean LED in interval 4 if air detected.
 - Check OWI sense for the presence of bulk soil during pause interval 9; execute APF, and turn on clean LED in interval 8 if bulk soil detected.
-

5. Thermistor (temperature sensor) checks - turn clean LED on if thermistor is in its normal temperature range (32°F to 167°F [0°C to 75°C]). Turn sanitized LED on if fill temperature is above 65°F (18.3°C).
-

6. Turn on Sanitized LED in this interval to indicate that the Salt Level Reed Switch is closed.
-

7. Turn on Clean LED in this interval to indicate that vent current is detected.
-

Customer Cycle Operation

To quickly advance through customer cycles, invoke the Rapid Advance mode by pressing HIGH TEMP - HEATED DRY - HIGH TEMP - HEATED DRY, after starting the cycle. Then, press START/RESUME to advance through cycle intervals.

NOTE: Rapid Advance mode is automatically enabled in the Service Diagnostic cycle but must be manually invoked in customer cycles.

For Service Technician Use Only

Service Diagnostics With Error Codes

Entry Sequence:

Press **START/RESUME** to wake up the control panel. Press any 3 keys in the sequence 1-2-3-1-2-3-1-2-3 with no more than 1 second between key presses.

NOTE: Some models have replaced the “Clean” LED with “Completed.”

If no error, “Clean” LED stays on for 5 seconds or display shows “F-” or “E-”.

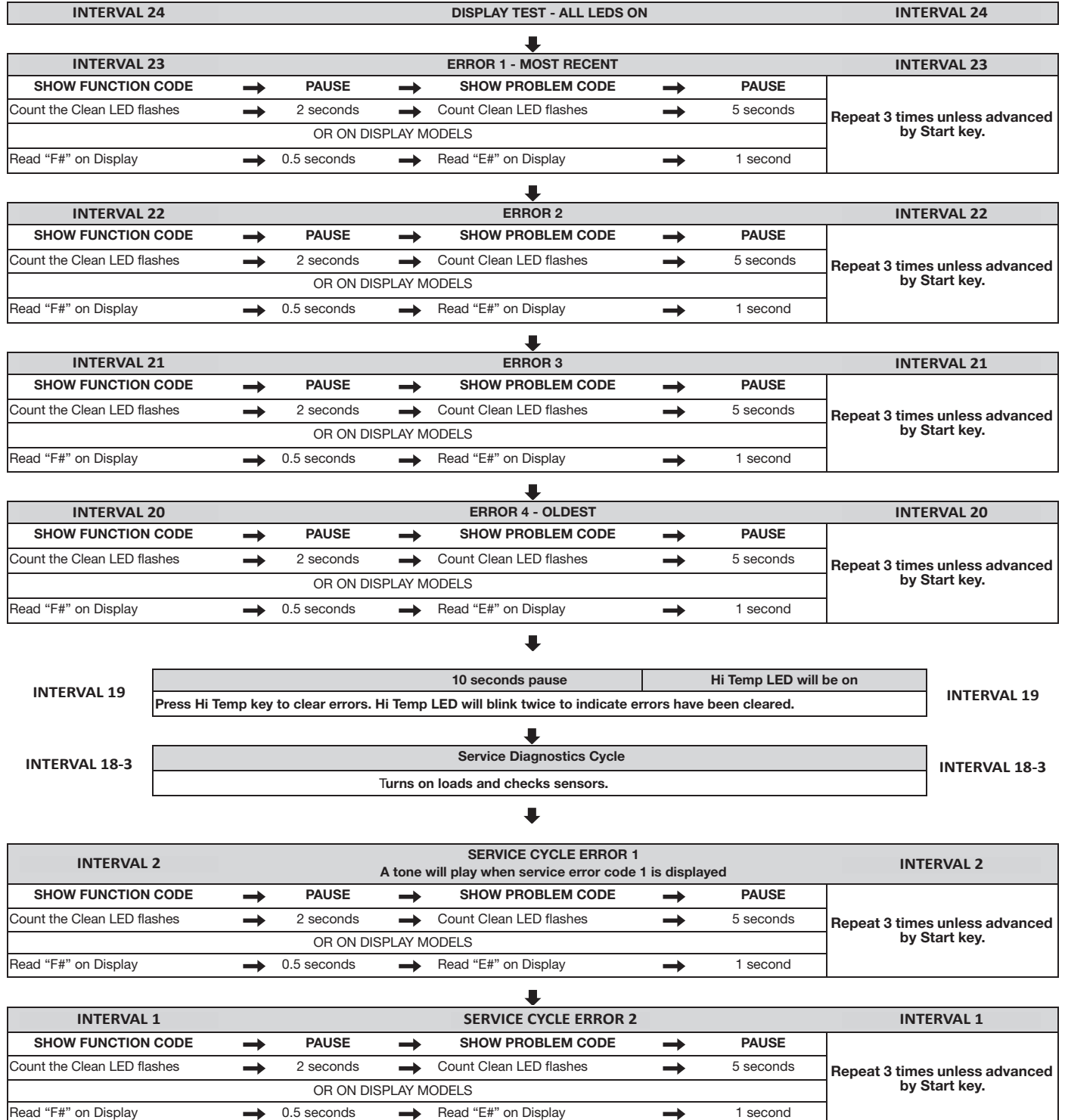

NOTE: Once error codes are extracted, refer to the “Service Error Codes” table to diagnose and correctly resolve the root cause condition.

For Service Technician Use Only

Service Error Codes

⚠ DANGER



Electrical Shock Hazard

Only authorized technicians should perform diagnostic voltage measurements.

After performing voltage measurements, disconnect power before servicing.

Failure to follow these instructions can result in death or electrical shock.

FUNCTION CODE	PROBLEM CODE	CAUSES	WHAT TO CHECK
1-CONTROL	1-PILOT STUCK ON	CONTROL DETECTED K2 PILOT RELAY STUCK CLOSED.	<ol style="list-style-type: none"> 1. UNPLUG DISHWASHER OR DISCONNECT POWER. 2. CHECK ALL LOADS ON K2 PILOT RELAY FOR SHORTS. 3. REPLACE CONTROL AND ALL SHORTED COMPONENTS.
	2-CONTROL SOFTWARE ISSUE	ALL LEDS ARE ON.	<ol style="list-style-type: none"> 1. UNPLUG DISHWASHER OR DISCONNECT POWER. 2. REPLACE UI. (FOR MODELS WITH NUMERIC DISPLAY ONLY).
		DAMAGED OR CORRUPTED MEMORY ON CONTROL BOARD; INCOMPATIBLE SOFTWARE COMPONENTS INSIDE MICRO.	<ol style="list-style-type: none"> 1. UNPLUG DISHWASHER OR DISCONNECT POWER. 2. REPLACE CONTROL BOARD.
2-USER INTERFACE	1-STUCK KEY	<p>CONTROL DETECTED STUCK KEY(S) IN KEYPAD OR KEYPAD CONNECTION.</p> <p>NOTE: IF ANY KEYS ARE STUCK, THE STUCK KEY(S) WILL BE IGNORED AND AN ERROR RECORDED TO SERVICE HISTORY, BUT NO ALERT TO CUSTOMER.</p>	<p>CHECK RESPONSIVENESS OF EACH KEY.</p> <ol style="list-style-type: none"> 1. IF SOME KEYS DO NOT RESPOND, THEN: <ul style="list-style-type: none"> - UNPLUG DISHWASHER OR DISCONNECT POWER. - DISASSEMBLE DOOR AND DISCONNECT KEYPAD CONNECTION FROM CONTROL OR LCD DISPLAY MODULE. - VERIFY ALL OTHER CONNECTIONS TO CONTROL ARE MADE. - REASSEMBLE DOOR BUT DO NOT CLOSE DOOR (LEAVE KEYPAD DISCONNECTED). - PLUG IN DISHWASHER OR RECONNECT POWER. - WAIT AT LEAST 7 SECONDS FOR CONTROL TO POWER UP COMPLETELY. - CLOSE DISHWASHER DOOR AND MONITOR CONTROL RESPONSE: <ol style="list-style-type: none"> A. IF CONTROL IS OK (NO LONGER SEES STUCK KEYS WITH KEYPAD UNPLUGGED), IT WILL RESPOND BY TURNING ON THE DRAIN MOTOR FOR 2 MINUTES. REPLACE KEYPAD AND CONSOLE. B. IF CONTROL IS NOT OK (STILL SEES STUCK KEYS WITH KEYPAD UNPLUGGED), IT WILL NOT TURN ON DRAIN MOTOR. WAIT FOR AT LEAST 10 SECONDS. IF STILL NO DRAIN RESPONSE, THEN REPLACE CONTROL OR LCD DISPLAY MODULE (WHICHEVER ONE THE KEYPAD WAS CONNECTED TO). C. IF ALL KEYS APPEAR OK OR INTERMITTENT, AND KEYPAD IS CAPACITIVE TOUCH TYPE, THEN: <ul style="list-style-type: none"> - VERIFY TUB BRACKETS ARE SCREWED TO UNDERSIDE OF COUNTERTOP AND NOT HANGING OVER KEYS (IF SCREW HEAD TOO CLOSE, RELOCATE SCREW TO ALTERNATE HOLE). - CHECK FOR EVIDENCE OF MOISTURE OR DEBRIS ON THE SURFACE OF THE KEYS. IF EVIDENT, CLEAN AND INSTRUCT CUSTOMER ABOUT KEEPING SURFACE CLEAN. - CHECK ERROR CODE HISTORY FOR FAN ERROR 10-3 AS POTENTIAL CAUSE OF CONDENSATION ON USER INTERFACE. - VERIFY PRESENCE OF VENT CURRENT IF MODEL HAS A VENT WAX MOTOR. REFER TO "LEAKS OR DRIPS ON CABINET OR FLOOR" IN THE "TROUBLESHOOTING GUIDE" SECTION.

For Service Technician Use Only

Service Error Codes (continued)

FUNCTION CODE	PROBLEM CODE	CAUSES	WHAT TO CHECK	
3-THERMISTOR/ OWI	1-OPEN	<ul style="list-style-type: none"> - OPEN CONNECTION OR COMPONENT IN TEMPERATURE SENSING CIRCUIT. - OPEN OR FAULTY TEMPERATURE SENSOR - TEMPERATURE SENSOR INPUT ON CONTROL. 	<ol style="list-style-type: none"> 1. CHECK OPERATION OF TEMPERATURE SENSOR IN SERVICE DIAGNOSTICS CYCLE. 2. UNPLUG DISHWASHER OR DISCONNECT POWER. 3. CHECK ALL COMPONENTS AND CONNECTIONS IN THE TEMPERATURE SENSING CIRCUIT WITH METER, FIX/REPLACE OPEN CONNECTION/PART. 	
	2-SHORTED	<ul style="list-style-type: none"> - INCOMING WATER TEMPERATURE ABOVE 167F(75 C) - SHORTED CONNECTION OR COMPONENT IN TEMPERATURE SENSING CIRCUIT. - SHORTED OR FAULTY TEMPERATURE SENSOR. - TEMPERATURE SENSOR INPUT ON CONTROL. 	<ol style="list-style-type: none"> 1. CHECK INCOMING WATER TEMPERATURE. 2. CHECK OPERATION OF TEMPERATURE SENSOR IN SERVICE DIAGNOSTICS CYCLE. 3. UNPLUG DISHWASHER OR DISCONNECT POWER. 4. CHECK ALL COMPONENTS AND CONNECTIONS IN THE TEMPERATURE SENSING CIRCUIT WITH METER, FIX/REPLACE SHORTED WIRES/PART. (SEE OWI SENSOR STRIP CIRCUIT) 	
	3-FAILED CALIBRATION	OWI FAILURE		<ol style="list-style-type: none"> 1. RUN SERVICE DIAGNOSTICS TO CHECK OWI OPERATION. OWI SHOULD SEE LOW SOIL WITH CLEAR WATER. 2. CHECK OWI LENS SURFACE. CLEAN IF NEEDED. 3. UNPLUG DISHWASHER OR DISCONNECT POWER. 4. CHECK ALL CONNECTIONS IN SOIL SENSING CIRCUIT WITH METER. FIX/REPLACE BAD CONNECTION/PART. <p>NOTE: RUN DIAGNOSTICS CYCLE AFTER INSTALLING NEW OWI TO FORCE CALIBRATION ON NEXT REGULAR WASH CYCLE.</p>
		DRAIN HOSE CHECK VALVE NOT SEALING.		<p>DIRTY WATER BACKS INTO DISHWASHER AFTER DRAINING.</p> <ol style="list-style-type: none"> 1. DISCONNECT DRAIN HOSE AT PLUMBING CONNECTION. 2. ELEVATE HOSE ABOVE DISHWASHER AND FILL WITH WATER. IF WATER FLOWS INTO DISHWASHER, REPLACE ENTIRE DRAIN LOOP (INSTALL AS HIGH AS POSSIBLE AND ATTACH TO UNDERSIDE OF COUNTERTOP IF POSSIBLE).
4-WASH MOTOR	3-MOTOR NOT RUNNING	LOOSE CONNECTION IN MOTOR CIRCUIT AND/OR FAULTY WASH MOTOR.	<ol style="list-style-type: none"> 1. CHECK OPERATION OF WASH MOTOR DURING DIAGNOSTICS. 2. UNPLUG DISHWASHER OR DISCONNECT POWER. 3. CHECK RESISTANCES OF CONNECTIONS IN THE WASH CIRCUIT. <ul style="list-style-type: none"> - IF HIGH RESISTANCE, CHECK/FIX LOOSE CONNECTIONS OR REPLACE WASH MOTOR. 	
		CONTROL MOTOR DRIVE CIRCUIT OR SENSE CIRCUIT.	<ol style="list-style-type: none"> 1. UNPLUG DISHWASHER OR DISCONNECT POWER. 2. IF METER CHECK OF WASH MOTOR CIRCUIT SHOWS NORMAL RESISTANCE AND STILL NOT GETTING POWER TO THE WASH MOTOR, REPLACE CONTROL. 	
5-DOOR SWITCH	1-DOOR STUCK OPEN	DOOR WAS NOT LATCHED WITHIN 4 SECONDS OF PRESSING THE START / RESUME KEY.	INSTRUCT CUSTOMER. REFER TO USE & CARE GUIDE.	
		<p>LOOSE CONNECTION IN DOOR SWITCH CIRCUIT AND/OR DOOR SWITCH CONTACTS STUCK OPEN AND/OR DOOR SWITCH NOT MAKING CONTACT:</p> <ul style="list-style-type: none"> - SLOPPY DOOR LATCH ASSEMBLY (WHICH CAN BE AGGRAVATED BY HIGH DOOR CLOSURE FORCE KEEPING STRIKE PLATE FROM FULLY SEATING). - DOOR SWITCH (HIGH RESISTANCE). 	<ol style="list-style-type: none"> 1. CHECK STRIKE PLATE AND DOOR CLOSURE FORCE. VERIFY DOOR SEAL IS SEATED PROPERLY. CHECK FOR INTERFERENCE BETWEEN DISH RACKS AND DOOR. TRY BENDING STRIKE PLATE DOWN FOR BETTER ENGAGEMENT. 2. UNPLUG DISHWASHER OR DISCONNECT POWER. 3. CHECK RESISTANCES OF DOOR SWITCH CONTACTS AND ALL CONNECTIONS IN THE DOOR SWITCH CIRCUIT WITH METER, WHILE OPENING AND CLOSING THE DOOR LATCH. <ul style="list-style-type: none"> - IF HIGH RESISTANCE WITH DOOR CLOSED, CHECK/FIX LOOSE CONNECTIONS. <ol style="list-style-type: none"> 4. MEASURE RESISTANCE OF DOOR SWITCH CONTACTS WHILE CHECKING MECHANICAL OPERATION OF LATCH ASSEMBLY. CHECK FOR BROKEN PLASTIC PIECES ON LATCH ASSEMBLY. REPLACE LATCH IF FAULTY. 	
		IF NONE OF THE ABOVE	<ol style="list-style-type: none"> 1. UNPLUG DISHWASHER OR DISCONNECT POWER. 1. CHECK FOR 13 VDC FROM P9-5 TO P9-6 BY COMPLETING THE FOLLOWING STEPS: <ol style="list-style-type: none"> A. CONNECT VOLTAGE MEASUREMENT EQUIPMENT. B. PLUG IN DISHWASHER OR RECONNECT POWER AND VERIFY 13 VDC. C. IF NO VOLTAGE IS PRESENT, UNPLUG DISHWASHER OR DISCONNECT POWER AND REPLACE CONTROL. 	

For Service Technician Use Only

Service Error Codes (continued)

FUNCTION CODE	PROBLEM CODE	CAUSES	WHAT TO CHECK
5-DOOR SWITCH (CONTINUED)	2-DOOR STUCK CLOSED	CONTROL PROGRAMMED TO NOT START IF IT SUSPECTS THE DOOR SWITCH IS STUCK CLOSED. CONTROL LOOKS FOR THE DOOR SWITCH TO OPEN BETWEEN CYCLES. - CUSTOMER DIDN'T OPEN THE DOOR BETWEEN CYCLES OR DOOR SWITCH CONTACTS STUCK CLOSED.	1. OPEN AND CLOSE DOOR AND THEN PRESS START/RESUME KEY. IF WORKS NOW, INSTRUCT CUSTOMER TO OPEN DOOR BETWEEN CYCLES. 2. UNPLUG DISHWASHER OR DISCONNECT POWER. 3. MEASURE RESISTANCE OF DOOR SWITCH CONTACTS WHILE CHECKING MECHANICAL OPERATION OF LATCH ASSEMBLY.
6-INLET WATER	1-LOW/NO WATER (MECHANICAL PROBLEM)	NO WATER TO DISHWASHER.	VERIFY WATER SUPPLY IS TURNED ON AND SUPPLY LINE ADEQUATE.
		BOWLS OR POTS LOADED OR FLIPPED UPSIDE DOWN AND CAPTURED WASH WATER.	INSTRUCT CUSTOMER ON LOADING. REFER TO USE AND CARE GUIDE.
		DRAIN LOOP DETACHED FROM TUB AND/OR IMPROPER DRAIN CONNECTION.	CHECK FOR WATER SIPHONING OUT OF UNIT: 1. ALLOW DISHWASHER TO COMPLETE NORMAL FILL. 2. DRAIN FOR 5-10 SECONDS BY PRESSING CANCEL/DRAIN. 3. OPEN DOOR AND CONFIRM WATER DOES NOT SIPHON OUT OF UNIT. IF IT DOES, CONFIRM DRAIN LOOP IS ATTACHED TO SIDE OF DISHWASHER AND DRAIN HOSE IS CONNECTED TO A DRAIN AT LEAST 20 INCHES (50.8 CM) OFF THE FLOOR.
		WATER LEAKING FROM DISHWASHER	CHECK FOR LEAKS UNDER DISHWASHER.
		FILL VALVE OR WATER LINE PLUGGED WITH DEBRIS.	TURN OFF WATER SUPPLY TO DISHWASHER, DISCONNECT WATER LINE TO INLET VALVE AND INSPECT/CLEAN THE INLET SCREEN OF FILL VALVE AND RECONNECT WATER.
		OVERFILL SWITCH STUCK IN "OVERFILL" POSITION AND/OR DISHWASHER NOT LEVEL.	CHECK OTHER ERROR CODES TO SEE IF 6-4 ALSO OCCURRED. SEE 6-4 ERROR CODE BELOW.
		FILL VALVE ELECTRICAL PROBLEM.	CHECK OTHER ERROR CODES TO SEE IF 6-2 ALSO OCCURRED. SEE 6-2 ERROR CODE BELOW.
	2-FILL VALVE ELECTRICAL PROBLEM	LOOSE CONNECTION IN FILL VALVE CIRCUIT AND/OR OPEN FILL VALVE SOLENOID.	UNPLUG DISHWASHER OR DISCONNECT POWER AND CHECK RESISTANCES OF FILL VALVE SOLENOID AND ALL CONNECTIONS IN THE FILL CIRCUIT WITH METER. FIX/REPLACE OPEN CONNECTION / PART.
		OPEN FUSE ON CONTROL TO FILL VALVE.	REFER TO "FUSE SERVICE CHECK" ON PAGE 3-4 IN "TESTING" SECTION.
		FILL VALVE DRIVE CIRCUIT ON THE CONTROL.	UNPLUG DISHWASHER OR DISCONNECT POWER AND REPLACE CONTROL.
	3-SUDS/AIR IN PUMP	TOO MANY SUDS.	1. ALLOW UNIT TO FILL AND WASH FOR 1 MINUTE. OPEN DOOR AND CHECK FOR EXCESSIVE SUDSING. 2. CONFIRM USING PROPER DISHWASHER DETERGENT, NOT HAND DETERGENT. 3. CHECK FOR EXCESSIVE RINSE AID LEAKAGE.
		BOWLS OR POTS LOADED OR FLIPPED UPSIDE DOWN AND CAPTURED WASH WATER.	INSTRUCT CUSTOMER ON LOADING. REFER TO USE AND CARE MANUAL.
		WATER LEAKING FROM DISHWASHER.	CHECK FOR LEAKS UNDER DISHWASHER.
	4-FLOAT SWITCH OPEN	OVERFILL SWITCH STUCK IN "OVERFILL" POSITION AND/OR DISHWASHER NOT LEVEL.	REMOVE ANY ITEMS STUCK UNDER FLOAT. VERIFY THAT THE FLOAT MOVES FREELY AND YOU HEAR THE "CLICK" OF THE SWITCH CONTACTS. CHECK/ADJUST LEVEL OF THE DISHWASHER.
		DRAIN HOSE CHECK VALVE NOT SEALING.	WATER BACKS INTO DISHWASHER AFTER DRAINING AND ELEVATES WATER LEVEL. 1. DISCONNECT DRAIN HOSE AT PLUMBING CONNECTION. 2. ELEVATE HOSE ABOVE DISHWASHER AND FILL WITH WATER. IF WATER FLOWS INTO DISHWASHER, REPLACE ENTIRE DRAIN LOOP (INSTALL AS HIGH AS POSSIBLE AND ATTACH TO UNDERSIDE OF COUNTERTOP IF POSSIBLE).

For Service Technician Use Only

Service Error Codes (continued)

FUNCTION CODE	PROBLEM CODE	CAUSES	WHAT TO CHECK
6-INLET WATER (CONTINUED)	4-FLOAT SWITCH OPEN (CONTINUED)	FILL VALVE TRIAC ON CONTROL SHORTED.	IF STILL FILLING WHILE DOOR IS OPEN, FILL VALVE IS MECHANICALLY STUCK OPEN (SEE BELOW). IF NOT FILLING WITH THE DOOR OPEN, CHECK OPERATION IN SERVICE DIAGNOSTICS TEST CYCLE. ADVANCE SERVICE CYCLE UNTIL DETERGENT DISPENSER OPENS. FILL VALVE SHOULD BE OFF. LISTEN TO SEE IF DISHWASHER STILL FILLING. IF STILL FILLING, UNPLUG DISHWASHER OR DISCONNECT POWER AND REPLACE CONTROL.
		FILL VALVE MECHANICALLY STUCK OPEN.	CONFIRM DISHWASHER FILLS WHILE DOOR IS OPEN. IF YES, UNPLUG DISHWASHER OR DISCONNECT POWER, TURN OFF WATER TO DISHWASHER, REPLACE FILL VALVE. AND TURN WATER BACK ON.
		TOO MANY SUDS.	<ol style="list-style-type: none"> 1. ALLOW UNIT TO FILL AND WASH FOR 1 MINUTE. OPEN DOOR AND CHECK FOR EXCESSIVE SUDSING. 2. INSTRUCT CUSTOMER IF USING IMPROPER DISHWASHER DETERGENT (HAND DETERGENT). 3. DISCONNECT POWER & REPLACE DISPENSER IF SEE EXCESSIVE RINSE AID LEAKAGE.
		OPEN FUSE F9 TO FILL VALVE AND OTHER TRIAC LOADS.	REFER TO "FUSE SERVICE CHECK" ON PAGE 3-4 IN "TESTING" SECTION.
	7-FLOWMETER	DISCONNECTED OR DAMAGED FLOWMETER	<ol style="list-style-type: none"> 1. DISCONNECT POWER OR UNPLUG UNIT. 2. CHECK CONNECTIONS AT SALT LEVEL SENSOR AND AT FLOWMETER. 3. USE METER TO CHECK FOR FLOWMETER SWITCH CLOSED. USE METER TO CHECK SALT LEVEL SENSOR. SWITCH IS OPEN WHEN SALT RESERVOIR IS FILLED AND CLOSED WHEN SALT RESERVOIR IS LOW/EMPTY. 4. DISCONNECT FLOWMETER AND LEAVE SALT SENSOR CONNECTED. APPLY A MAGNET TO SIDE OF THE SALT TANK NEAR THE SENSOR CONNECTION TO FORCE THE SWITCH CLOSED. 5. WITH THE MAGNET IN PLACE, RUN THE COMPLETE SERVICE DIAGNOSTICS CYCLE. IF THE SANITIZED LED TURNS ON IN INTERVAL 3, THE CONTROL IS GOOD; REPLACE THE FLOWMETER ASSEMBLY. IF THE SANITIZED LED DOES NOT TURN ON, THE CONTROL INPUT HAS FAILED; REPLACE THE CONTROL.
	8-WATER SOFTENER REGEN VALVE - ELECTRICAL PROBLEM (WATER SOFTENER MODELS ONLY)	LOOSE CONNECTION IN REGEN VALVE CIRCUIT, AND/OR OPEN REGEN VALVE SOLENOID.	UNPLUG DISHWASHER OR DISCONNECT POWER AND CHECK RESISTANCES OF REGEN VALVE SOLENOID AND ALL CONNECTIONS IN THE REGEN VALVE CIRCUIT. FIX/REPLACE OPEN CONNECTION/PART.
		OPEN FUSE ON CONTROL TO REGEN VALVE.	REFER TO "FUSE SERVICE CHECK" ON PAGE 3-4 IN "TESTING" SECTION.
REGEN VALVE DRIVE CIRCUIT ON THE CONTROL.		UNPLUG DISHWASHER OR DISCONNECT POWER AND REPLACE CONTROL.	
7-HEATING	1-NO HEAT	CONTROL PROGRAMMED TO DISABLE HEATER, BUT CONTINUE RUNNING CYCLES, IF IT DETECTS A WATER HEATING PROBLEM.	RUNNING DIAGNOSTICS CLEARS THE CONTROL AND ALLOWS THE HEATER TO TURN ON AGAIN, WATER HEATING PROBLEM MUST BE CORRECTED, OR THE CONTROL WILL DISABLE THE HEATER AGAIN. SEE "HEATER CIRCUIT" PROBLEM BELOW.
		HEATER CIRCUIT PROBLEM: - OPEN IN HEATER. - OPEN CONNECTION OR COMPONENT IN HEATER CIRCUIT.	<ol style="list-style-type: none"> 1. UNPLUG DISHWASHER OR DISCONNECT POWER. 2. MEASURE RESISTANCE OF HEATER AND ALL COMPONENTS AND CONNECTIONS IN WATER HEATING CIRCUIT/ HEAT DRY CIRCUIT. FIX/REPLACE OPEN CONNECTION/PART.
		HEATER DRIVE CIRCUIT ON THE CONTROL.	UNPLUG DISHWASHER OR DISCONNECT POWER AND REPLACE CONTROL.
	2-HEATER STUCK ON	HEATER DRIVE CIRCUIT ON THE CONTROL.	<ol style="list-style-type: none"> 1. UNPLUG DISHWASHER OR DISCONNECT POWER AND REPLACE CONTROL. 2. INSPECT HEATER AND CONNECTIONS FOR OVERHEATING/ SHORTING. IF EVIDENCE OF OVERHEATING OR SHORTS EXISTS, REPLACE.

For Service Technician Use Only

Service Error Codes (continued)

FUNCTION CODE	PROBLEM CODE	CAUSES	WHAT TO CHECK
8-DRAINING	1-SLOW DRAIN	OBSTRUCTED DRAIN HOSE OR PATH	1. UNPLUG DISHWASHER OR DISCONNECT POWER. 2. CHECK FOR BLOCKAGES FROM SUMP CHECK VALVE TO CUSTOMER'S PLUMBING. POTENTIAL ITEMS, PLUGGED GARBAGE DISPOSER OR PLUG NOT KNOCKED OUT, DRAIN LOOP CHECK VALVE STUCK, AND/OR PLUGGED HOSES.
		DRAIN PUMP IMPELLER FRACTURED	1. UNPLUG DISHWASHER OR DISCONNECT POWER. 2. REMOVE DRAIN PUMP AND CHECK IMPELLER (NORMALLY THERE IS SOME UNEVEN RESISTANCE). IF IT IS STRIPPED, REPLACE DRAIN PUMP.
	2-DRAIN MOTOR ELECTRICAL PROBLEM	LOOSE CONNECTION IN DRAIN MOTOR CIRCUIT AND/OR OPEN DRAIN MOTOR WINDING.	UNPLUG DISHWASHER OR DISCONNECT POWER AND CHECK RESISTANCES OF DRAIN MOTOR WINDING AND ALL CONNECTIONS IN THE DRAIN CIRCUIT. FIX/REPLACE OPEN CONNECTION/PART.
		DEBRIS STUCK IN DRAIN MOTOR IMPELLER.	1. UNPLUG DISHWASHER OR DISCONNECT POWER. 2. REMOVE DRAIN MOTOR AND DISLodge DEBRIS FROM IMPELLER.
		OPEN FUSE ON CONTROL TO DRAIN MOTOR.	REFER TO "FUSE SERVICE CHECK" ON PAGE 3-4 IN "TESTING" SECTION.
		DRAIN MOTOR DRIVE CIRCUIT ON THE CONTROL.	UNPLUG DISHWASHER OR DISCONNECT POWER AND REPLACE CONTROL.
	3-DRAIN STUCK ON	DRAIN MOTOR DRIVE CIRCUIT ON THE CONTROL.	1. UNPLUG DISHWASHER OR DISCONNECT POWER AND REPLACE CONTROL. 2. INSPECT DRAIN MOTOR AND CONNECTIONS FOR OVERHEATING/SHORTING. IF EVIDENCE OF OVERHEATING/SHORTING EXISTS, REPLACE.
10-OTHER	1-DISPENSER ELECTRICAL PROBLEM	LOOSE CONNECTION IN DISPENSER CIRCUIT AND/OR OPEN DISPENSER SOLENOID.	UNPLUG DISHWASHER OR DISCONNECT POWER AND CHECK RESISTANCES OF DISPENSER SOLENOID AND ALL CONNECTIONS IN THE DISPENSER CIRCUIT. FIX/REPLACE OPEN CONNECTION/PART.
		OPEN FUSE ON CONTROL TO DISPENSER.	REFER TO "FUSE SERVICE CHECK" ON PAGE 3-4 IN "TESTING" SECTION.
		DISPENSER DRIVE CIRCUIT ON THE CONTROL.	UNPLUG DISHWASHER OR DISCONNECT POWER AND REPLACE CONTROL.
	3-DRYING FAN ERROR	LOOSE CONNECTION IN FAN CIRCUIT AND/OR OPEN FAN MOTOR.	UNPLUG DISHWASHER OR DISCONNECT POWER AND CHECK RESISTANCES OF FAN MOTOR AND ALL CONNECTIONS IN THE FAN CIRCUIT. FIX/REPLACE OPEN CONNECTIONS OR FAN.
		FAN DRIVE CIRCUIT ON THE CONTROL.	UNPLUG DISHWASHER OR DISCONNECT POWER AND REPLACE CONTROL.

For Service Technician Use Only

Troubleshooting Guide

⚠ DANGER

<p>Electrical Shock Hazard</p> <p>Only authorized technicians should perform diagnostic voltage measurements.</p> <p>After performing voltage measurements, disconnect power before servicing.</p> <p>Failure to follow these instructions can result in death or electrical shock.</p>

NOTES:

- For resistance checks, refer to the “Dishwasher Strip Circuits” in Section 3.
- For checking operation with diagnostics, refer to “Service Diagnostics Cycle” section.

CUSTOMER DESCRIPTION	POTENTIAL CAUSES	CHECK	ERROR CODES
CLEAN LED FLASHES	CONTROL PROGRAMMED WITH SELF DIAGNOSTICS.	READ FUNCTION CODE FROM THE DISHWASHER AND REFER TO FUNCTION CODES PORTION OF ERROR CODE TABLE. RUN SERVICE DIAGNOSTICS TEST CYCLE TO READ FULL HISTORY OF ERROR CODES.	
WON'T RUN or POWER UP (“DEAD” KEYPAD/CONSOLE) - NO OPERATION - NO KEYPAD RESPONSE - NO LEDS OR DISPLAY	NO POWER TO UNIT OR BAD CONNECTION.	CHECK FUSES, CIRCUIT BREAKERS AND JUNCTION BOX CONNECTIONS.	
	LOOSE CONNECTIONS IN DISHWASHER POWER UP CIRCUIT OR BETWEEN KEYPAD(S) AND CONTROL.	1. UNPLUG DISHWASHER OR DISCONNECT POWER. 2. CHECK CONTINUITY POWER CONNECTIONS TO CONTROL AND CONNECTIONS BETWEEN KEYPAD(S) AND CONTROL.	
	MODEL HAS AN LCD DISPLAY AND THE CONTROL HAS BEEN EXCHANGED FOR ONE THAT IS NOT COMPATIBLE WITH THE LCD DISPLAY MODULE.	VERIFY CORRECT CONTROL IS INSTALLED. CONTROL SHOULD HAVE NO 4-PIN USER INTERFACE CONNECTOR PRESENT AT P1B IF IT IS CONFIGURED FOR AN LCD MODEL . UNPLUG DISHWASHER OR DISCONNECT POWER AND REPLACE CONTROL.	5-1
	CONTROL DETECTED DOOR SWITCH PROBLEM.	1. UNPLUG DISHWASHER OR DISCONNECT POWER. 2. REFER TO “SERVICE ERROR CODES TABLE.”	
	USER INTERFACE OR CONTROL	1. UNPLUG DISHWASHER OR DISCONNECT POWER. DISASSEMBLE DOOR AND INSPECT CONTROL POWER CONNECTOR (P4) AND ADJACENT PC BOARD FOR DAMAGE. REPLACE AS NEEDED. 2. REFER TO “SERVICE ERROR CODES TABLE” FOR STUCK KEY (2-1). RUN THE DIAGNOSTIC CHECK, ITEM (1). - IF DRAIN MOTOR TURNS ON, CONTROL IS OK. REPLACE THE UI. - IF DRAIN MOTOR DOES NOT RUN ON, REPLACE CONTROL. 3. INSPECT UI CABLE FOR LOOSE OR DAMAGED WIRING. REPLACE AS NEEDED. 4. INSPECT UI ASSEMBLY FOR DAMAGE OR CONTAMINATION. REPLACE UI AS NEEDED.	
WON'T RUN AND LED FOR START/RESUME KEY IS BLINKING SLOWLY	BY DESIGN, IF THE DOOR IS OPENED FOR MORE THAN 5 SECONDS OR POWER IS INTERRUPTED DURING A CYCLE, THE USER MUST PRESS THE START/RESUME KEY TO RESUME OPERATION.	INSTRUCT CUSTOMER. REFER TO USE & CARE MANUAL.	
	START/RESUME KEY NOT RESPONDING.	SEE “ONE OR MORE KEYS WON'T RESPOND”.	
	CONTROL DETECTED DOOR SWITCH PROBLEM.	REFER TO SERVICE ERROR CODES TABLE.	5-1

For Service Technician Use Only

Troubleshooting Guide (continued)

CUSTOMER DESCRIPTION	POTENTIAL CAUSES	CHECK	ERROR CODES
WON'T RUN <u>AND</u> ALL LEDS ON	SOFTWARE/HARDWARE INCOMPATIBILITY PROBLEM WITH CONTROL.	REFER TO SERVICE ERROR CODES TABLE.	1-2
WON'T START AND START/RESUME KEY LED FLASHES 3 TIMES WHEN START/RESUME KEY IS PRESSED	CONTROL LOOKING FOR DOOR TO OPEN BETWEEN CYCLES: - CUSTOMER HAS NOT OPENED DOOR SINCE LAST CYCLE. - DOOR SWITCH CONTACTS STUCK CLOSED.	REFER TO SERVICE ERROR CODES TABLE.	5-2
WON'T ACCEPT KEY PRESSES AND CONTROL LOCK LED ON	CONTROL LOCKOUT FEATURE ACCIDENTALLY TURNED ON BY CUSTOMER.	INSTRUCT CUSTOMER. REFER TO USE & CARE GUIDE (PRESS & HOLD CONTROL LOCK KEY 5 SEC TO TURN ON/OFF).	
ONE OR MORE KEYS WON'T RESPOND OR UNUSUAL LED/ DISPLAY / KEY BEHAVIOR	STUCK KEY OR SHORT CIRCUIT(S) IN KEYPAD OR IN CONTROL'S INPUT LINES THAT READ THE KEYS.	REFER TO SERVICE ERROR CODES TABLE.	2-1
	CAPACITIVE TOUCH KEYPAD ADHESIVE COMING LOOSE FROM CONSOLE.	1. UNPLUG DISHWASHER OR DISCONNECT POWER. 2. INSPECT KEYPAD BOARD FOR SEPARATION FROM CONSOLE. REPLACE KEYPAD AND CONSOLE IF SEPARATION IS SEEN.	
	LOOSE CONNECTIONS BETWEEN KEYPAD AND CONTROL AND / OR BENT OR CONTAMINATED CONNECTOR PINS.	1. UNPLUG DISHWASHER OR DISCONNECT POWER. 2. INSPECT CONNECTIONS IN USER INTERFACE CIRCUITS. RECONNECT LOOSE CONNECTIONS. REPLACE PART(S) IF PINS DAMAGED OR CONTAMINATED.	2-2
	EXCESSIVE CONDENSATION ON USER INTERFACE PARTS DUE TO VENT AND/OR FAN PROBLEM.	CHECK ERROR HISTORY FOR 10-3 FAN ERROR. REFER TO SERVICE ERROR CODES TABLE. VERIFY PRESENCE OF VENT IF MODEL HAS A VENT WAX MOTOR. REFER TO "LEAKS OR DRIPS ON CABINET OR FLOOR" IN THE "TROUBLESHOOTING GUIDE" SECTION.	10-3
	FOR MODELS WITH A CAPACITIVE TOUCH KEYPAD ON THE FRONT OF UNIT, CONTROL PANEL IS IN "SLEEP MODE" WHERE ALL KEYS (EXCEPT START/RESUME AND CANCEL/DRAIN) ARE DISABLED AFTER 30 SECONDS OF INACTIVITY.	TO WAKE UP THE CONTROL PANEL, PRESS START/RESUME OR CANCEL/DRAIN, OR OPEN AND CLOSE THE DOOR. 1. PRESS AND VERIFY ALL KEYS RESPOND. INSTRUCT CUSTOMER REGARDING "SLEEP MODE." 2. IF KEYS STILL DO NOT RESPOND, REPLACE KEYPAD AND CONSOLE.	
	DEFECTIVE USER INTERFACE	1. UNPLUG DISHWASHER OR DISCONNECT POWER. 2. REPLACE USER INTERFACE CONSOLE ASSEMBLY.	
DISHWASHER BEEPS CONSTANTLY (FOR MODELS WITH BEEPERS)	USER OPENED DOOR DURING CYCLE AND CLOSED DOOR WITHOUT PRESSING START/RESUME TO RESUME CYCLE.	INSTRUCT CUSTOMER. DISHWASHER CONTROL IS DESIGNED TO BEEP IF DISHWASHER IS IN "CYCLE INTERRUPT" MODE WITH DOOR LATCHED. CONTROL WILL STOP BEEPING WHEN DOOR IS OPENED AND/OR START/RESUME KEY IS PRESSED TO RESUME CYCLE.	
	NORMAL BEEPER OPERATION IS EXCESSIVE TO CUSTOMER.	INSTRUCT CUSTOMER HOW TO TURN BEEPER OFF AND ON. PRESS AND HOLD HI TEMP KEY FOR 3 SECONDS (TONE SOUNDS).	
LONG CYCLES AND/OR STUCK IN CERTAIN PART OF CYCLE	AS PART OF NORMAL OPERATION, THE DISHWASHER PAUSES 2 OR 3 TIMES DURING THE CYCLE FOR THERMAL HOLDS AND ADVANCES ONCE TEMPERATURE IS MET.	INSTRUCT CUSTOMER. EXPLAIN THERMAL HOLDS AND HOW THE CYCLE PAUSES WHEN THEY OCCUR.	
	OWI SOIL SENSOR PICKING HIGH SOIL CYCLE TOO OFTEN.	1. RUN SERVICE DIAGNOSTICS CYCLE TO CHECK IF OWI SHOWING HIGH SOIL WITH CLEAR WATER. 2. CHECK LENS SURFACE. CLEAN IF NEEDED. 3. UNPLUG DISHWASHER OR DISCONNECT POWER. 4. REPLACE OWI & RUN DIAGNOSTICS AFTER INSTALLING NEW OWI TO FORCE CALIBRATION ON NEXT WASH CYCLE.	
	A WATER HEATING PROBLEM COULD CAUSE LONG CYCLES BUT WILL TYPICALLY CAUSE A "WATER HEATING FAULT".	REFER TO SERVICE ERROR CODES TABLE.	7-1
	HEATER TAKES A LONG TIME TO HEAT WATER WITH LOW VOLTAGE.	CHECK FOR AT LEAST 100 VAC AT POWER SOURCE.	

For Service Technician Use Only

Troubleshooting Guide (continued)

CUSTOMER DESCRIPTION	POTENTIAL CAUSES	CHECK	ERROR CODES
LONG CYCLES AND/OR STUCK IN CERTAIN PART OF CYCLE (CONTINUED)	INCOMING WATER UNDER 84° F (29° C)	1. BE SURE DISHWASHER IS CONNECTED TO THE HOT WATER SUPPLY. 2. CONFIRM TEMPERATURE AT SINK. RECOMMEND 120° F (49° C). INSTRUCT CUSTOMER TO RUN WATER AT SINK BEFORE RUNNING DISHWASHER. 3. UNPLUG DISHWASHER OR DISCONNECT POWER AND CHECK ALL CONNECTIONS AND MEASURE RESISTANCE IN TEMPERATURE SENSING CIRCUIT. REPLACE OWI IF RESISTANCE IS HIGH.	
	SUDS OR AIR IN PUMP REQUIRES REPEATED WASH PERIODS.	REFER TO SERVICE ERROR CODES TABLE.	6-3
	OWI OR NTC SENSOR PROBLEM.	REFER TO SERVICE ERROR CODES TABLE.	3-1 3-3
LEDS OR DISPLAYS RUN FOR SHORT TIME (BUT NO LOADS RUNNING) AND THEN SHUTS OFF	UNIT IS IN SALES DEMO MODE.	CHECK OPERATION OF CANCEL KEY; IF NO CANCEL LED RESPONSE TO MULTIPLE CANCEL KEY PRESSES, THE CONTROL IS LIKELY IN SALES DEMO MODE. RUN SERVICE DIAGNOSTICS CYCLE TO CLEAR DEMO MODE.	
	OPEN F9 (TRIAC LOAD FUSE) ON CONTROL DISABLED LOADS.	REFER TO "FUSE SERVICE AND RESISTANCE CHECKS" ON PAGE 3-4 IN "TESTING" SECTION.	
CAN START A CYCLE BUT ONLY RUNS FOR A SHORT TIME - CYCLE DOES NOT COMPLETE (CLEAN LED OR COMPLETED MAY BLINK)	CONTROL CANCELLED CYCLE DUE TO ERROR DETECTED WITH WASH MOTOR OR LOW WATER.	REFER TO SERVICE ERROR CODES TABLE.	4-3, 6-1 6-2, 6-3 6-4, 8-3
	UNIT IN SALES DEMO MODE	RUN SERVICE DIAGNOSTICS CYCLE TO CLEAR DEMO MODE.	
WILL NOT DRAIN OR EXCESS WATER LEFT IN DISHWASHER. NOTE: CHECK ERROR HISTORY. IF NO ERROR CODES FOR ELECTRICAL PROBLEMS, PROBLEM IS MECHANICAL. DO NOT REPLACE CONTROL.	DRAIN LOOP CHECK VALVE NOT SEALING.	1. DISCONNECT DRAIN HOSE AT PLUMBING CONNECTION. 2. ELEVATE HOSE ABOVE DISHWASHER AND FILL WITH WATER. IF WATER FLOWS INTO DISHWASHER, REPLACE ENTIRE DRAIN LOOP. INSTALL AS HIGH AS POSSIBLE.	
	CUSTOMER MISUNDERSTANDS WATER LEVEL AFTER DRAIN.	INSTRUCT CUSTOMER. SUMP WILL NORMALLY HAVE ABOUT 1 INCH (2.4 CM) OF WATER REMAINING IN FILTER CUP HOLE AFTER CYCLE.	
	DRAINING PROBLEM	REFER TO SERVICE ERROR CODES TABLE.	8-1, 8-2
DETERGENT NOT DISPENSING OR DETERGENT LEFT IN DISPENSER NOTE: CHECK ERROR HISTORY IF NO ERROR CODES FOR ELECTRICAL PROBLEMS, PROBLEM IS MECHANICAL. DO NOT REPLACE CONTROL	ITEM IN LOWER RACK BLOCKED LID OR BLOCKED SPRAY OF WATER TO DISPENSER.	INSTRUCT CUSTOMER ON PROPER DISH LOADING.	
	MECHANICAL BINDING OF DISPENSER LID.	1. UNPLUG DISHWASHER OR DISCONNECT POWER. 2. CHECK/REPLACE DISPENSER.	
	LID LATCH BINDING DUE TO EXCESS DETERGENT IN MECHANISM.	INSTRUCT CUSTOMER ON PROPER DISPENSER FILLING.	
	DISPENSER ELECTRICAL PROBLEM	REFER TO SERVICE ERROR CODES TABLE.	10-1
	CONTROL CANCELLED CYCLE BEFORE DISPENSING DUE TO ERROR DETECTED WITH WASH MOTOR OR LOW WATER.	REFER TO SERVICE ERROR CODES TABLE.	4-3, 6-1 6-2, 6-3 6-4, 8-3

For Service Technician Use Only

Troubleshooting Guide (continued)

CUSTOMER DESCRIPTION	POTENTIAL CAUSES	CHECK	ERROR CODES
POOR WASH	CYCLE SELECTION OF CUSTOMER NOT APPROPRIATE FOR DISH LOAD.	INSTRUCT CUSTOMER ON CYCLE SELECTION. RECOMMEND "HIGH TEMP" OPTION FOR WASH PERFORMANCE BOOST.	
	SPRAY ARMS NOT ROTATING OR PLUGGED.	1. CHECK ARM ROTATION. IF ARMS BLOCKED BY DISH ITEM, INSTRUCT CUSTOMER. ALSO CHECK FOR CORRECT UPPER SPRAY ARM ALIGNMENT WITH DOCKING STATION LOCATED ON FEED TUBE AT BACK TUB WALL. 2. CHECK NOZZLES; IF THEY ARE PLUGGED, CLEAN NOZZLES AND CONFIRM FILTERS INSTALLED PROPERLY.	
	POOR WASH DUE TO DRAINING AND/OR DISPENSING.	SEE "WILL NOT DRAIN OR EXCESS WATER LEFT IN UNIT", OR "DETERGENT NOT DISPENSING OR DETERGENT LEFT IN DISPENSER."	
	CONTROL CANCELLED CYCLE DUE TO ERROR DETECTED WITH WASH MOTOR, FLOAT SWITCH, LOW WATER OR SUDS.	REFER TO "SERVICE ERROR CODES TABLE." NOTE: EVEN IF NO ERROR CODE RECORDED, CONFIRM OWI PASSES ALL OWI CHECKS IN SERVICE DIAGNOSTICS CYCLE, AND SEE CHECKS FOR ERROR 3-3.	4-3, 6-1 6-2, 6-3 6-4, 8-3
	SOIL SENSOR PROBLEM	REFER TO SERVICE ERROR CODES TABLE NOTE: EVEN IF NO ERROR CODE RECORDED, CONFIRM OWI PASSES ALL OWI CHECKS IN SERVICE DIAGNOSTICS CYCLE AND SEE CHECKS FOR ERROR 3-3.	3-2 3-3
	HEATING PROBLEM	REFER TO "SERVICE ERROR CODES TABLE."	7-1
	SOFTENER PROBLEM (ON SOME MODELS)	REFER TO "SERVICE ERROR CODES TABLE."	6-8
FILM OR SPOTS ON GLASSES AND/OR DISHES	CUSTOMER NOT USING RINSE AID OR DISPENSER EMPTY	CHECK RINSE AID GAGE LEVEL ON DISPENSER. INSTRUCT CUSTOMER HOW TO FILL AND MONITOR ADD OR USE RINSE AID.	
	RINSE AID DISPENSER PROBLEM.	REFER TO "SERVICE ERROR CODES TABLE."	10-1
	HARD WATER LEAVING FILM ON DISHES.	CHECK WATER HARDNESS. IF HARD, INSTRUCT CUSTOMER TO USE MAXIMUM DETERGENT OR TRY POURING 1/4 CUP (60 mL) OF GLASS MAGIC INTO BOTTOM OF DISHWASHER. ALSO RECOMMEND THE 1HR WASH CYCLE.	
		FOR MODELS WITH WATER SOFTENER: CHECK FOR "ADD SALT" LED AT END OF CYCLE. IF ON, ADD SALT AND INSTRUCT CUSTOMER.	
		FOR MODELS WITH WATER SOFTENER: REGEN VALVE ELECTRICAL PROBLEM; REFER TO SERVICE ERROR CODES TABLE.	6-8
	DETERGENT CARRYOVER OR OVER-SUDSING.	CHECK WATER HARDNESS. IF BELOW 10 GRAINS, THEN INSTRUCT CUSTOMER TO USE LESS DETERGENT AND RECOMMEND THE "1 HR WASH" CYCLE.	6-3
	ETCHING OF GLASS FROM TOO MUCH DETERGENT AT TOO HIGH OF TEMPERATURE.	CHECK WATER HARDNESS. IF BELOW 10 GRAINS, THEN INSTRUCT CUSTOMER TO USE LESS DETERGENT AND RECOMMEND THE "1 HR WASH" CYCLE.	
DRAIN LOOP CHECK VALVE NOT SEALING.	1. DISCONNECT DRAIN HOSE AT PLUMBING CONNECTION. 2. ELEVATE HOSE ABOVE DISHWASHER AND FILL WITH WATER. IF WATER FLOWS INTO DISHWASHER, REPLACE ENTIRE DRAIN LOOP. INSTALL AS HIGH AS POSSIBLE AND ATTACH TO UNDERSIDE OF COUNTERTOP IF POSSIBLE.		

For Service Technician Use Only

Troubleshooting Guide (continued)

CUSTOMER DESCRIPTION	POTENTIAL CAUSES	CHECK	ERROR CODES
POOR DRY	CUSTOMER NOT USING RINSE AID AND/OR DISPENSER EMPTY.	CHECK RINSE AID GAUGE LEVEL ON DISPENSER; INSTRUCT CUSTOMER HOW TO FILL AND MONITOR, ADD OR USE RINSE AID.	
	CUSTOMER NOT USING HEATED DRY OPTION.	RECOMMEND USE OF HEATED DRY OR SMART DRY TO CUSTOMER.	
	RINSE AID DISPENSER PROBLEM	REFER TO "SERVICE ERROR CODES TABLE."	10-1
	VENT STUCK CLOSED DUE TO PILOT RELAY STUCK ON (NOT ALL MODELS).	REFER TO "SERVICE ERROR CODES TABLE."	1-1
	FAN PROBLEM (ON MODELS WITH FAN)	REFER TO "SERVICE ERROR CODES TABLE."	10-3
	CONTROL CANCELLED CYCLE DUE TO ERROR DETECTED WITH WASH MOTOR, FLOAT SWITCH, LOW WATER OR SUDS.	REFER TO "SERVICE ERROR CODES TABLE."	4-3, 6-1 6-2, 6-3 6-4, 8-3
	HEATING PROBLEM	REFER TO "SERVICE ERROR CODES TABLE."	7-1
SANITIZED LED BLINKS OR INCOMPLETE SANITIZATION MESSAGE AT END OF CYCLE (CONTROL COULD NOT CONFIRM SANITIZATION ACHIEVED)	DOOR OPENED DURING FINAL RINSE OR DRY.	INSTRUCT CUSTOMER.	
	INCOMING WATER UNDER 84° F (29° C)	1. BE SURE DISHWASHER IS CONNECTED TO THE HOT WATER SUPPLY. 2. CONFIRM TEMPERATURE AT SINK. RECOMMEND 120° F (49° C). INSTRUCT CUSTOMER TO RUN WATER AT SINK BEFORE RUNNING DISHWASHER. 3. UNPLUG DISHWASHER OR DISCONNECT POWER AND CHECK ALL CONNECTIONS AND MEASURE RESISTANCE IN TEMPERATURE SENSING CIRCUIT. REPLACE OWI IF RESISTANCE IS HIGH.	
	HEATING PROBLEM	REFER TO "SERVICE ERROR CODES TABLE."	7-1
	THERMISTOR / OWI SENSOR PROBLEM	REFER TO "SERVICE ERROR CODES TABLE."	3-1, 3-2
	INTERMITTENT DOOR SWITCH / LATCH CONNECTION.	SEE SAME CHECKS AS FOR 5-1 ERROR. REFER TO "SERVICE ERROR CODES TABLE."	
	LINE VOLTAGE TOO LOW TO HEAT FAST ENOUGH.	CHECK POWER SOURCE. CONFIRM AT LEAST 100 VAC.	
	AIR PRESSURE SURGES IN DISHWASHER DUE TO WASHING WITH HIGH SUDS CAUSES BRIEF OPENING OF DOOR SWITCH CONTACTS DURING FINAL RINSE.	REFER TO "SERVICE ERROR CODES TABLE."	6-3
MELTED DISHWARE AND/OR SPRAY ARM AND/OR DISHWASHER ALWAYS HOT	CUSTOMER USES NON-DISHWASHER SAFE DISHES OR LOADS PLASTIC DISHES DIRECTLY OVER HEATER.	INSTRUCT CUSTOMER.	
	TEMPERATURE SENSING PROBLEM.	REFER TO "SERVICE ERROR CODES TABLE."	3-1
	WATER HEATING PROBLEM, HEATER STUCK ON.	REFER TO "SERVICE ERROR CODES TABLE."	7-2
	WATER HEATER DISPLACED FROM MOUNTING CLIP AND / OR PULLED OFF CENTER.	INSPECT HEATER. ADJUST BACK INTO POSITION IF NEEDED.	

For Service Technician Use Only

Troubleshooting Guide (continued)

CUSTOMER DESCRIPTION	POTENTIAL CAUSES	CHECK	ERROR CODES
NOISY OPERATION	SPRAY ARM STALLED OR BLOCKED AND SPRAYING ON THE DOOR.	- INSTRUCT CUSTOMER IF BLOCKED. - CHECK SPRAY ARM ROTATION AND INSPECT FOR PLUGGED NOZZLES. IF PLUGGED, CLEAN NOZZLES AND CONFIRM FILTERS INSTALLED PROPERLY.	
	NO OR LOW WATER	REFER TO "SERVICE ERROR CODES TABLE."	6-1, 6-2 6-3, 6-4
	DRAINS TOO LONG	1. LONG DRAIN DUE TO OWI SENSOR PROBLEM. "REFER TO SERVICE ERROR CODES TABLE" FOR 3-3. 2. SLOW DRAIN PROBLEM. "REFER TO SERVICE ERROR CODES TABLE" FOR 8-1.	3-3, 8-1
	LOOSE CONNECTION IN VENT CIRCUIT AND/OR OPEN VENT WAX MOTOR.	UNPLUG DISHWASHER OR DISCONNECT POWER AND CHECK RESISTANCES OF VENT WAX MOTOR AND ALL CONNECTIONS IN THE VENT CIRCUIT. FIX/REPLACE OPEN CONNECTION/PART.	
	OPEN FUSE ON CONTROL TO VENT	REFER TO "FUSE SERVICE CHECK" ON PAGE 3-4 IN "TESTING" SECTION.	
	VENT DRIVE CIRCUIT ON CONTROL	UNPLUG DISHWASHER OR DISCONNECT POWER AND REPLACE CONTROL.	
	FAN RUNS (MAKES NOISE) AFTER CYCLE COMPLETED (ON MODELS WITH FAN).	DISHWASHER IS DESIGNED TO KEEP FAN RUNNING AFTER CYCLE TO PREVENT MOISTURE BUILDUP IN DISHWASHER. FAN WILL TURN OFF IF DOOR IS OPENED LONGER THAN 5 SEC. INSTRUCT CUSTOMER.	
	EXCESSIVE FAN NOISE DUE TO FAULTY FAN (ON MODELS WITH FAN).	1. CHECK FAN OPERATION DURING SERVICE DIAGNOSTICS TEST CYCLE. 2. UNPLUG DISHWASHER OR DISCONNECT POWER. 3. REPLACE FAN IF DOES NOT SPIN FREELY.	
LEAKS OR DRIPS ON CABINET OR FLOOR	LOOSE CONNECTION IN VENT CIRCUIT AND/OR OPEN VENT WAX MOTOR.	UNPLUG DISHWASHER OR DISCONNECT POWER AND CHECK RESISTANCES OF VENT WAX MOTOR AND ALL CONNECTIONS IN THE VENT CIRCUIT. FIX/REPLACE OPEN CONNECTION/PART.	
	OPEN FUSE ON CONTROL TO VENT.	REFER TO "FUSE SERVICE CHECK" ON PAGE 3-4 IN "TESTING" SECTION.	
	VENT DRIVE CIRCUIT ON CONTROL.	UNPLUG DISHWASHER OR DISCONNECT POWER AND REPLACE CONTROL.	
	FAN PROBLEM (ON MODELS WITH FAN)	REFER TO "SERVICE ERROR CODES TABLE."	10-3
	TOO MANY SUDS	REFER TO "SERVICE ERROR CODES TABLE."	6-3, 6-4
	LEAKING DISHWASHER	CHECK DOOR/TUB GASKET AND ALL WATER CONNECTIONS UNDER DISHWASHER. REFER TO "SERVICE ERROR TABLE."	6-1, 6-3
	UNIT NOT LEVEL (LEANING FORWARD) AND WATER SURGES OVER FRONT LIP DURING CYCLE.	CHECK ERROR HISTORY FOR FLOAT ERROR 6-4. ERROR 6-4 IS LIKELY TO OCCUR IF UNIT IS SIGNIFICANTLY OUT OF LEVEL AND LEANING FORWARD. REFER TO "SERVICE ERROR TABLE."	6-4
	AIR PRESSURE SURGE WHEN DOOR IS OPENED AND IMMEDIATELY CLOSED WHILE DISHWASHER IS HOT CAN FORCE DROPLETS OUT THE VENT DUCT.	INSTRUCT CUSTOMER TO LEAVE DOOR OPEN A FEW MINUTES BEFORE RE-CLOSING IF OPENED WHILE DISHWASHER IS HOT.	

Section 3: Testing

This section provides a wiring diagram, control board specifications, testing procedures and strip circuits the “Maytag Chopper Dishwashers.”

- Testing Safety
- Wiring Diagram
- Control Board Information
- General Theory of Operation
- Power Check
- Door Switch Circuit
- Fill Circuit
- Dispenser Circuit
- Water Heating/Heat Dry
- Water Sensing with the OWI Sensor
- Wash/Rinse Motor
- Drain Motor
- Vent Wax Motor (not on all models)
- Vent Fan (not on all models)
- AC Fan Motor (not on all models)
- Power Blast (not on all models)
- User Interface (UI)

For Service Technician Use Only

⚠ DANGER



Electrical Shock Hazard

Only authorized technicians should perform diagnostic voltage measurements.

After performing voltage measurements, disconnect power before servicing.

Failure to follow these instructions can result in death or electrical shock.

⚠ WARNING



Electrical Shock Hazard

Disconnect power before servicing.

Replace all parts and panels before operating.

Failure to do so can result in death or electrical shock.

Voltage Measurement Safety Information

When performing live voltage measurements, you must do the following:

- Verify the controls are in the off position so that the appliance does not start when energized.
- Allow enough space to perform the voltage measurements without obstructions.
- Keep other people a safe distance away from the appliance to prevent potential injury.
- Always use the proper testing equipment.
- After voltage measurements, always disconnect power before servicing.

IMPORTANT: Electrostatic Discharge (ESD) Sensitive Electronics

ESD problems are present everywhere. Most people begin to feel an ESD discharge at approximately 3000V. It takes as little as 10V to destroy, damage, or weaken the main control assembly. The new main control assembly may appear to work well after repair is finished, but a malfunction may occur at a later date due to ESD stress.

- Use an anti-static wrist strap. Connect wrist strap to green ground connection point or unpainted metal in the appliance

-OR-

- Touch your finger repeatedly to a green ground connection point or unpainted metal in the appliance.
- Before removing the part from its package, touch the anti-static bag to a green ground connection point or unpainted metal in the appliance.
- Avoid touching electronic parts or terminal contacts; handle electronic control assembly by edges only.
- When repackaging main control assembly in anti-static bag, observe above instructions.

IMPORTANT SAFETY NOTICE — “For Technicians only”

This service data sheet is intended for use by persons having electrical, electronic, and mechanical experience and knowledge at a level generally considered acceptable in the appliance repair trade. Any attempt to repair a major appliance may result in personal injury and property damage. The manufacturer or seller cannot be responsible, nor assume any liability for injury or damage of any kind arising from the use of this data sheet.

For Service Technician Use Only

⚠ DANGER



Electrical Shock Hazard

Only authorized technicians should perform diagnostic voltage measurements.

After performing voltage measurements, disconnect power before servicing.

Failure to follow these instructions can result in death or electrical shock.

Control Board Information

SPECIFICATIONS

ELECTRICAL SUPPLY:

(Under Load): 60Hz 120V AC

SUPPLY WATER FLOW RATE:

To fill 2 qt (1.9 L) in 27 seconds, 120 psi maximum, 20 psi minimum.

SUPPLY WATER TEMPERATURE:

120°F (49°C) (Before starting a cycle, run water from sink faucet until hot.)

WATER CHARGE:

1.58 gal. (6.0 L) Approximate

LOWER SPRAY ARM ROTATION:

12 TO 40 rpm

UPPER SPRAY ARM ROTATION:

12 TO 30 rpm

Fuse Service & Resistance Check

F9 = SMALL-TRIAC LOAD FUSE

Check operation of loads during the Service Diagnostics cycle.

- If any of the TRIAC loads work, F9 Fuse is OK.
- If all TRIAC loads fail to work, F9 Fuse could be open. See Fuse Resistance Check.”

FUSE RESISTANCE CHECK:

1. Unplug the dishwasher or disconnect power.
2. Measure resistance of F9 Fuse.

NOTE: Fuses are on the bottom of the Control Board but can be checked from the top side. See “Control Pinout” diagram.

- If resistance is $< 3 \Omega$, then fuse is OK.
- If resistance is $> 3 \Omega$, then fuse is open.

IF THE FUSE IS OPEN:

Inspect and check resistance of all loads on fuse. If any loads are open, shorted, or have evidence of overheating or pinched wires, replace loads and/or repair wires.

Component Testing

TESTING DISHWASHER COMPONENTS FROM THE CONTROL

Before testing any of the components, perform the following checks:

- The most common cause for misdiagnosed control failure is poor connections. Therefore, disconnecting, inspecting and reconnecting wires will be necessary throughout test procedures.
- All tests/checks should be made with a VOM or DVM having a sensitivity of 20,000 ohms-per-volt DC, or greater.
- Check all connections before replacing components, looking for broken or loose wires, failed terminals, or wires not pressed into connectors far enough.
- Voltage checks must be made with all connectors attached to the boards.
- Resistance checks must be made with power cord unplugged or power disconnected, and with wiring harness or connectors disconnected from the control.
- The testing procedures in this section may require the use of needle probes to measure voltage. Failure to use needle probes will damage the connectors.

For Service Technician Use Only

ELECTRONIC CONTROL BOARD

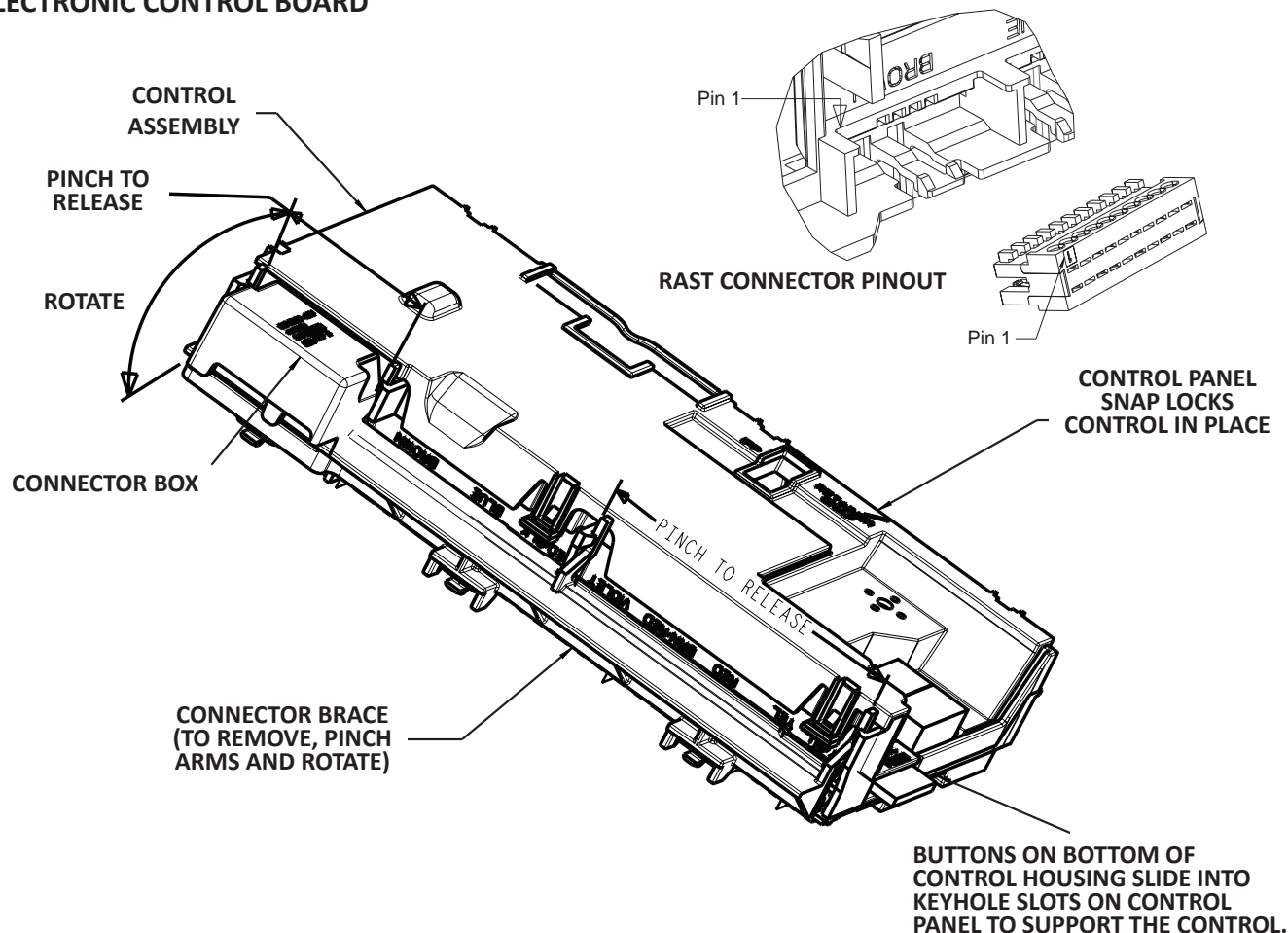

METER CHECK OF LOADS & SUPPLIES

IMPORTANT: Load must be connected for triac to operate correctly. Meter checks best made at the control

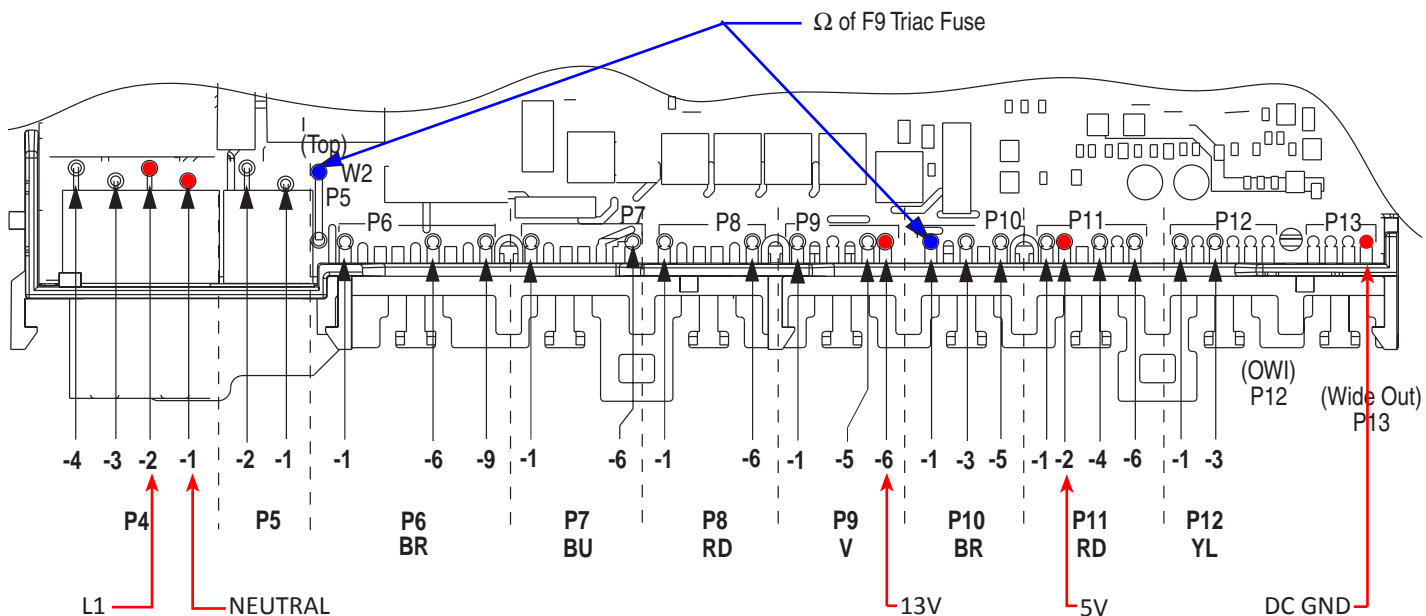

For Service Technician Use Only

⚠ DANGER



Electrical Shock Hazard

Only authorized technicians should perform diagnostic voltage measurements.

After performing voltage measurements, disconnect power before servicing.

Failure to follow these instructions can result in death or electrical shock.

General Theory of Operation

Refer to Wiring Diagram on page 6-3.

Neutral and L1 (AC voltage) enters the Control Board at P4, pins 1 & 2 respectively. AC is converted to DC voltage at the Low Volts Power Supply (LVPS). Supplies include 13 and 5 VDC, and DC GND (REF). These low voltage supplies are used to provide power to the microprocessors and board components, control the TRIACs, power the sensors, buzzer, fan motor, and energize the AC relays.

The 13 VDC is vital to the operation of the dishwasher. This supply is necessary to operate all 120 VAC loads in the dishwasher, whether they are connected to a relay or controlled by TRIACs. 13 VDC is generated by the power supply and flows through the door switch—when closed—to be available to the heater relays (L1 & N), wash motor relay, and the pilot relay. A relay coil becomes energized when the control closes the LV drive circuit for a specific relay completing 13V pathway, which in turn closes the relay switch providing AC to the load. The Pilot relay provides “L1” to the remainder of the components that are controlled by the Neutral-sensed TRIACs.

In the chopper dishwasher, there is one fuse on the Control Board: **F9 Small-TRIAC Load Fuse**. If the TRIAC Fuse is open, all loads controlled by TRIACs will not operate.

NOTE: Refer to “Fuse Service and Diagnostic Checks” on page 3-4.

Power Check

This test checks for incoming and outgoing power to and from the control board. This test assumes that proper voltages is present at the outlet or direct connect cable.

Test Procedure

1. Unplug dishwasher or disconnect power.
2. Remove access panel.
3. Remove terminal box cover.
4. With a voltmeter set to AC, insert black probe inside white wire screw nut (N) and insert red probe inside black wire screw nut (L1).
5. Plug in dishwasher or reconnect power.
 - If 120 VAC is present, unplug dishwasher or disconnect power and proceed to step 6.
 - If 120 VAC is not present, have customer correct power problem at outlet or breaker.
6. Remove outer door panel.
7. Remove cover from control board and locate connector P4.
8. With a voltmeter set to AC, connect black probe to P4, pin 1 (N) and red probe to P4, pin 2 (L1).
9. Plug in dishwasher or reconnect power.
 - If 120 VAC is present, go to step 10.
 - If 120 VAC is not present, check for open connection between terminal block and control. Repair as needed.
10. Verify DC Supplies
 - **5 VDC** is used to power IC’s and micro-processors on the circuit board as well as provide power to the sensors and fan motor.
 - If **5 VDC** were missing, the Fan Motor and OWI (Optical Water Indicator) would not function. To verify $5V \pm 5\%$, with a voltmeter set to DC, connect the black lead to P13-4 (DC GND) and the red lead to P11-2 (5V).
 - **13 VDC** is used to actuate the 120 VAC relays and TRIACs on the control.
 - If **13 VDC** was missing, the heater, motors, and all other loads would not turn on. To verify $13V \pm 5\%$, with a voltmeter set to DC, connect the black lead to P13-4 (DC GND) and the red lead to P9-6 (13V).
- Troubleshooting Missing DC Supplies:** Refer to the wiring diagram on page 3-3 when troubleshooting the DC supplies. If 5 VDC or 13 VDC is missing on the control, unplug dishwasher or disconnect power, and then disconnect all components/loads from the control relying on the missing or loaded supply. Plug in dishwasher or reconnect power and check if the DC supply has returned.
 - If not, replace the control.
 - If it has, turn off dishwasher and reconnect one connector at a time until the component loading down that supply has been identified.
11. Unplug dishwasher or disconnect power.
12. Reassemble all parts and panels.

For Service Technician Use Only

⚠ DANGER



Electrical Shock Hazard

Only authorized technicians should perform diagnostic voltage measurements.

After performing voltage measurements, disconnect power before servicing.

Failure to follow these instructions can result in death or electrical shock.

Door Switch Circuit

Perform the following checks if the dishwasher does not detect the door open or closed. This test will check the wiring to the door switch and the door switch itself. The following items are part of the door switch circuit.

- Harness/Connection
- Door Switch/Latch Assembly
- Control Board

Test Procedure

1. Check for improper installation of the dishwasher or leveling. Check door latch mechanism for obstructions or binding. Verify door seal is seated properly. Check for interference between dish racks and door. Repair as necessary.
2. Unplug dishwasher or disconnect power.
3. Remove outer door panel to access door latch and control board.

4. Check door switch contacts and all connections in the door switch circuit. Visually check that the P9 connector on the control and the door latch connector are securely installed.
 - If visual check passes, go to step 5.
 - If any of the connectors are not inserted properly, reconnect and retest door latch/switch.
5. Disconnect connector P9 from the control board.
6. Using an ohmmeter, measure across P9, pins 5 and 6 with the door closed, strike completely in latch mechanism (switch closed).
 - If 3 ohms or less is measured, proceed to step 7.
 - If high resistance is measured when door is closed, check for loose connections and repair as needed.
7. Using an ohmmeter, measure across P9, pins 5 and 6 with the door open, strike removed from latch mechanism (switch open).
 - If reading is infinite, go to step 8.
 - If reading shows continuity, or door switch is damaged, replace door switch and retest.
8. Set voltmeter to DC and connect red lead to test-pad P9-6 (13V) and black lead to P13-4 (DC GND) on the control board.
9. Plug in dishwasher or reconnect power and with door open, verify that 13 VDC is present across P9-6 and P13-4.
 - If 13 VDC is not present, replace the control and retest.
 - If 13 VDC is present, proceed to step 10.
10. Reconnect P9 to control board and perform Diagnostic Cycle to verify operation.
11. Unplug dishwasher or disconnect power.
12. Reassemble all parts and panels.
13. Plug in dishwasher or reconnect power.

Strip Circuit – Door Switch

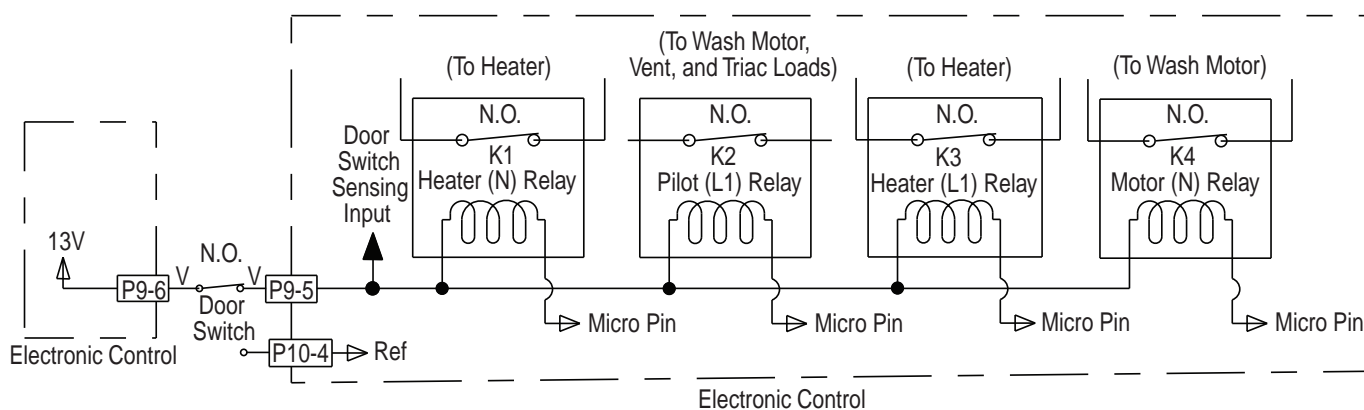

For Service Technician Use Only

⚠ DANGER



Electrical Shock Hazard

Only authorized technicians should perform diagnostic voltage measurements.

After performing voltage measurements, disconnect power before servicing.

Failure to follow these instructions can result in death or electrical shock.

Fill Circuit

This test will check the wiring and components in the fill circuit. The following items are part of the fill circuit.

- Harness/Connection
- Overfill Switch
- Fill Valve
- Control Board

Test Procedure

1. Verify water supply is turned on and supply line is adequate. Check for water siphoning out of the dishwasher (drain loop or improper drain connection). Check for debris in water line or fill valve inlet screen. Check for proper float switch operation. Repair as necessary.
2. Are all the loads controlled by TRIACs **not** working?
 - YES – check for open door switch, TRIAC fuse, or pilot relay.
 - NO – just the Fill Valve. Go to step 3.
3. Unplug dishwasher or disconnect power.

4. Remove outer door panel to access control board.
5. Unplug connector P6 from control board.
6. Check the fill valve and harness—using an ohmmeter, measure the resistance between P6-7 and P6-9.
 - If the resistance is between 890-1090 ohms, the fill valve and harness are good. Go to step 7.
 - If outside the range, replace the fill valve.
 - If an open circuit is detected, check connections and harness continuity between control and fill valve. If good, replace the fill valve.
7. Check the float (overflow) switch—using an ohmmeter, measure the resistance between P6-4 and P6-6 with the float switch closed/float down (normal position).
 - If 3 ohms or less is measured, go to step 8.
 - If an open circuit or high resistance is measured, check connections and harness continuity between the control and float switch. If harness is good, replace switch and retest.
8. Using an ohmmeter; measure the resistance between P6-4 and P6-6 with the float switch open/float up.
 - If reading is infinite, go to step 9.
 - If 3 ohms or less is measured, or float/overflow switch is damaged, replace switch and retest.
9. Reconnect P6 to control board.
10. Set voltmeter to AC and connect leads to test-pads P10-1 & P6-9 on the control board. Plug in dishwasher or reconnect power.
11. Start the Diagnostic Cycle and at the proper interval measure for AC out of the control between test-pads P10-1 & P6-9. (Refer to the Fill Valve Strip Circuit below.)

IMPORTANT: The Fill Valve must be connected to the control board to measure voltage accurately!!!

 - If no AC voltage is measured, replace the control board and retest.
 - If 120V AC is measured and fill valve is energized, go to step 12.
12. Unplug dishwasher or disconnect power.
13. Reassemble all parts and panels.
14. Plug in dishwasher or reconnect power and run Diagnostic Cycle to verify repair.

Strip Circuit – Fill

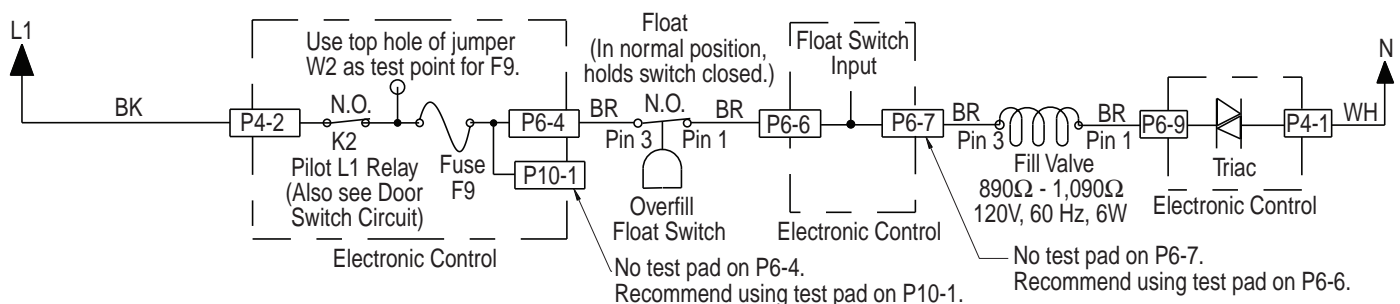

For Service Technician Use Only

⚠ DANGER



Electrical Shock Hazard

Only authorized technicians should perform diagnostic voltage measurements.

After performing voltage measurements, disconnect power before servicing.

Failure to follow these instructions can result in death or electrical shock.

Dispenser Circuit

This test will check the wiring to the dispenser and the dispenser solenoid or wax motor itself. The following items are part of the dispenser circuit.

- Harness/Connection
- Dispenser Solenoid/Wax Motor
- Control Board

Test Procedure

1. Check for obstructions or mechanical binding preventing the dispenser lid from opening. Repair or replace as necessary.
2. Are all the loads controlled by TRIACs **not** working?
 - YES – check for open door switch, TRIAC fuse, or pilot relay.
 - NO – just the Dispenser. Go to step 3.
3. Unplug dishwasher or disconnect power.

4. Remove outer door panel to access dispenser and remove toe and access panels to access control board.
5. Unplug connector P9 from control board.
6. Check the dispenser solenoid or wax motor (depending on model) and harness—using an ohmmeter, measure the resistance between P9-1 and P9-3.

Solenoid:

- If the resistance is between 260-300 ohms, the solenoid valve and harness are good. Go to step 7.
- If outside the range, replace the dispenser solenoid.
- If an open circuit is detected, check connections and harness continuity between control and dispenser. If good, replace the dispenser solenoid.

Wax Motor:

- If the resistance is between 1.4-3.0K ohms, the wax motor and harness are good. Go to step 7.
- If outside the range, replace the dispenser wax motor.
- If an open circuit is detected, check connections and harness continuity between control and dispenser. If good, replace the dispenser wax motor.

7. Reconnect P9 to control board.
8. Set voltmeter to AC and connect leads to test-pads P10-1 & P9-1 on the control board. Plug in dishwasher or reconnect power.
9. Start the Diagnostic Cycle and at the proper interval measure for AC out of the control between P10-1 to P9-1. (Refer to the Dispenser Strip Circuit below.)

IMPORTANT: The Dispenser Solenoid or Wax Motor must be connected to the control board to measure voltage accurately!!!

- If no AC voltage is measured, replace the control board and retest.
 - If 120 VAC is measured and dispenser motor/solenoid is energized, go to step 10.
10. Unplug dishwasher or disconnect power.
 11. Reassemble all parts and panels.
 12. Plug in dishwasher or reconnect power and run Diagnostic Cycle to verify repair.

Strip Circuit – Dispenser

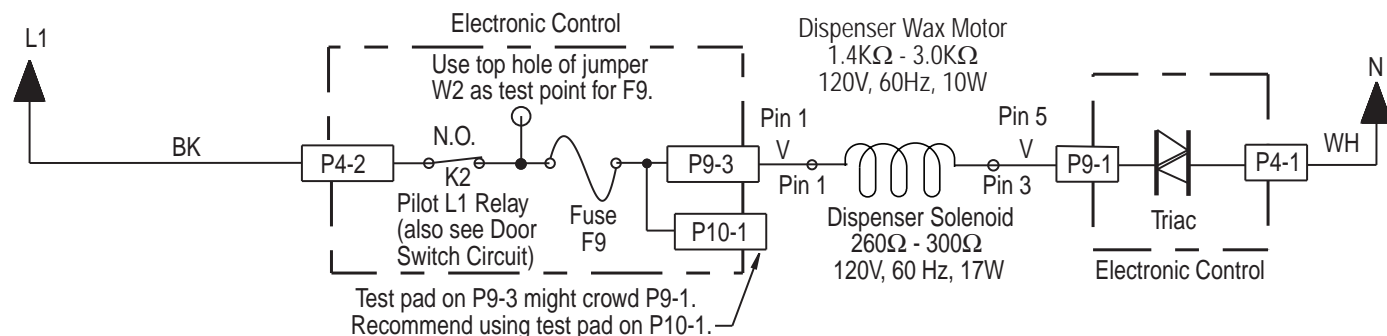

For Service Technician Use Only

⚠ DANGER



Electrical Shock Hazard

Only authorized technicians should perform diagnostic voltage measurements.

After performing voltage measurements, disconnect power before servicing.

Failure to follow these instructions can result in death or electrical shock.

4. Using an ohmmeter, measure resistance between P4, pins 3 and 4.
 - If the resistance is between 8-30 ohms, go to step 6.
 - If an open circuit is detected, go to step 5.
5. Visually check the wire connections between the control board, the heater element and the hi-limit thermostat. If the connections look good, check for continuity across the heater element and the hi-limit.
 - Replace heater element or hi-limit thermostat if it is electrically open.
 - Repair or replace wire harness if test fails continuity.
6. Reconnect P4 to control board.
7. Set voltmeter to AC and connect leads to test-pads P4-3 & P4-4 on the control board. Plug in dishwasher or reconnect power.
8. Start the Diagnostic Cycle and at the proper interval measure for AC out of the control between P4-3 and P4-4 using a voltmeter set to AC.
 - If 120 VAC is measured and heater element is on, go to step 9.
 - If no AC voltage is measured, replace control board.
9. Perform Diagnostic Cycle to verify repair.
 - If heater related error still exists, perform Water Sensing test procedure on following page.
10. Unplug dishwasher or disconnect power.
11. Reassemble all parts and panels.
12. Plug in dishwasher or reconnect power.

Water Heating/Heat Dry

This test will check the wiring to the heater element, hi-limit thermostat and the heating circuit itself. The following items are part of the heater circuit.

- Harness/Connection
- Heater Coil
- Hi Limit Thermostat
- Control Board

Test Procedure

Control may be programmed to disable the heater if it detects a problem with the heating system. Run Diagnostics to clear the control and allow the heater to turn on again. If heating problem is not corrected, the control will disable the heater again.

1. Unplug dishwasher or disconnect power.
2. Remove outer door panel to access control board.
3. Disconnect P4 from the control board.

Strip Circuit – Heater Circuit

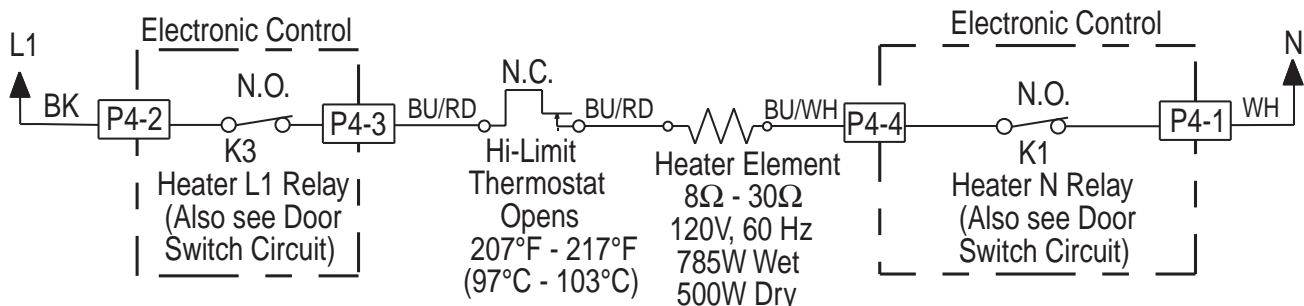

For Service Technician Use Only

⚠ DANGER



Electrical Shock Hazard

Only authorized technicians should perform diagnostic voltage measurements.

After performing voltage measurements, disconnect power before servicing.

Failure to follow these instructions can result in death or electrical shock.

TEMP °F (°C)	RES RANGE k ohms
77° F (25° C)	46 – 52k ohms
140° F (60° C)	11 – 13k ohms

NOTE: All thermistor resistance measurements must be made while dishwasher is unplugged or disconnected from power and connector P12 removed from control.

- If the thermistor resistance is OK , the thermistor is good. Go to step 6.
 - If the thermistor resistance does not agree with the table, replace the OWI Sensor.
 - If an open circuit is detected, check connections and harness continuity between control and OWI If good, replace the OWI Sensor.
6. Using an ohmmeter, check P12 -1 to cabinet ground and P12-3 to cabinet ground.
 - If no short is indicated, go to step 7.
 - If either pin indicates continuity to ground (short), repair or replace wiring harness and retest.
 7. Reconnect P12 to control board.
 8. Test for 5 VDC—With a voltmeter set to DC, connect the black lead to P12-2 and the red lead to P12-3.
 9. Plug in dishwasher or reconnect power.
 10. Start the Diagnostic Cycle and at the proper interval measure for 5 VDC out of the control between P12-2 and P12-3.
 - If 5 VDC is measured the control is functioning, go to step 11.
 - If no DC voltage is measured, replace the control board and retest.
 11. Unplug dishwasher or disconnect power.
 12. Reassemble all parts and panels.
 13. Plug in dishwasher or reconnect power and run Diagnostic Cycle to verify repair.

Water Sensing with the OWI Sensor

This test will check the wiring to the OWI (Optical Water Indicator), which incorporates the temperature thermistor and the foam & turbidity sensor. The following items are part of the water sensing circuit.

- Harness/Connection
- OWI Sensor
- Control Board

Test Procedure

1. Check the operation of the OWI Sensor in the Service Diagnostic Cycle.
2. Unplug dishwasher or disconnect power.
3. Remove outer door panel to access control board.
4. Disconnect P12 from the Control Board.
5. Using an ohmmeter, measure resistance between P12, pins 1 and 3. The following table provides approximate room and hot water temperatures and their associated resistance values.

Strip Circuit – Water Sensing

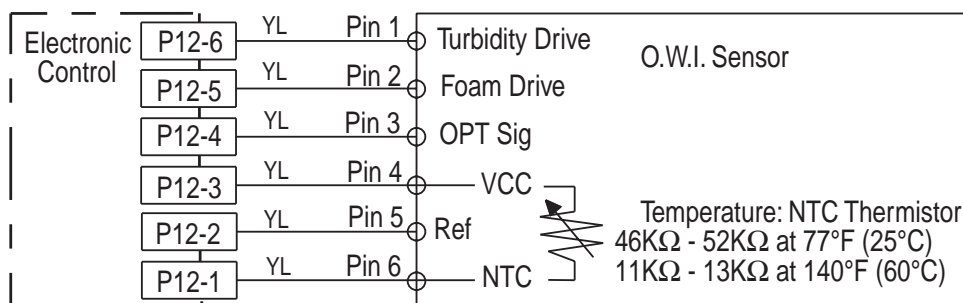

Measure NTC resistance at P12-1 and P12-3 connector disconnected from control.

For Service Technician Use Only

⚠ DANGER



Electrical Shock Hazard

Only authorized technicians should perform diagnostic voltage measurements.

After performing voltage measurements, disconnect power before servicing.

Failure to follow these instructions can result in death or electrical shock.

Wash/Rinse Motor

This test will check the wiring to the wash/rinse motor and the motor itself. The following items are part of the wash/rinse motor circuit.

- Harness/Connection
- Wash/Rinse Motor & Capacitor
- Control Board

Test Procedure

1. Check the tub and sump for anything that may be impeding water flow. Inspect and if necessary clean the coarse-filter system. Also, inspect spray arm water nozzles and clean if needed.
2. Check the wash/rinse motor and electrical connections by performing the Service Diagnostic Cycle. The following steps assume that this step was unsuccessful.
3. Unplug dishwasher or disconnect power.
4. Remove outer door panel to access control board.
5. Unplug connector P5 from control board.

6. Check the wash/rinse motor—using an ohmmeter, measure the resistance between P5-1 and P5-2.
 - If the resistance is between 10-15 ohms, the wash/rinse motor and harness are good. Go to step 7.
 - If outside the range, replace the wash/rinse motor.
 - If an open circuit is detected, check connections and harness continuity between control and wash/rinse motor. If good, replace the motor.
7. Reconnect P5 to control board.
8. Set voltmeter to AC and connect leads to test-pads P5-1 & P5-2 on the control board. Plug in dishwasher or reconnect power.
9. Start the Diagnostic Cycle and at the proper interval measure for AC out of the control between P5-1 & P5-2. (Refer to Wash Motor Strip Circuit below.)
 - If no AC voltage is measured, replace the control board and retest.
 - If 120 VAC is measured and wash/rinse motor is running, go to step 12.
 - If 120 VAC is measured and wash/rinse motor is not running, go to step 10.
10. Test the wash/rinse motor capacitor. **NOTE:** A faulty capacitor may cause the motor to “hum,” not start, or start slowly.
 - a. Discharge the capacitor by touching the leads of a 20,000 Ω resistor to the two terminals.
 - b. Disconnect the wires from the capacitor terminals.
 - c. With an ohmmeter, measure across the terminals and note reading.
 - If a steady increase in resistance is noted, capacitor is good. Replace wash motor assembly and retest.
 - If the capacitor is either shorted or open, replace capacitor. and retest.
11. If the preceding steps did not correct the wash/rinse motor problem, replace the control board.
12. Unplug dishwasher or disconnect power.
13. Reassemble all parts and panels.
14. Plug in dishwasher or reconnect power and run Diagnostic Cycle to verify repair.

Strip Circuit – Wash/Rinse

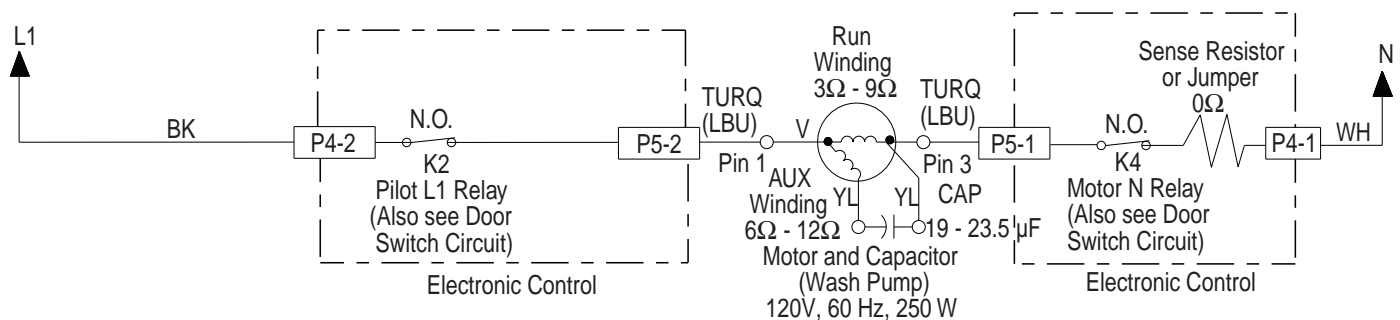

For Service Technician Use Only

⚠ DANGER



Electrical Shock Hazard

Only authorized technicians should perform diagnostic voltage measurements.

After performing voltage measurements, disconnect power before servicing.

Failure to follow these instructions can result in death or electrical shock.

Drain Motor

This test will check the wiring to the drain motor and the drain motor itself. The following items are part of the drain motor circuit.

- Harness/Connection
- Drain Motor
- Control Board

Test Procedure

1. Verify that drain hose or drain path is not obstructed. Check for blockage from sump check valve to customer's plumbing. Check for plugged garbage disposal or disposal plug not knocked out. Check drain loop, stuck check valve, or for plugged hoses. Repair as needed.
2. Check the drain motor and electrical connections by performing the Service Diagnostic Cycle. The following steps assume that this step was unsuccessful.

3. Are all the loads controlled by TRIACs **not** working?
 - YES – check for open door switch, TRIAC fuse, or pilot relay.
 - NO – just the drain motor. Go to step 4.
4. Unplug dishwasher or disconnect power.
5. Remove outer door panel to access control board.
6. Unplug connector P6 from control board.
7. Check the drain motor—using an ohmmeter, measure the resistance between P6-1 and P6-3.
 - If the resistance is between 15-60 ohms, the drain motor and harness are good. Go to step 8.
 - If outside the range, replace the drain motor.
 - If an open circuit is detected, check connections and harness continuity between control and drain motor. If good, replace the drain motor.
8. Reconnect P6 to control board.
9. Set voltmeter to AC and connect leads to test-pads P10-1 & P6-1 on the control board. Plug in dishwasher or reconnect power.
10. Start the Diagnostic Cycle and at the proper interval measure for AC out of the control between P10-1 & P6-1. (Refer to Drain Motor Strip Circuit below.)

IMPORTANT: The Drain Motor must be connected to the control board to measure voltage accurately!!!

 - If no AC voltage is measured, replace the control board and retest.
 - If 120 VAC is measured and drain motor is running, go to step 11.
11. Unplug dishwasher or disconnect power.
12. Reassemble all parts and panels.
13. Plug in dishwasher or reconnect power and run Diagnostic Cycle to verify repair.

Strip Circuit – Drain Motor

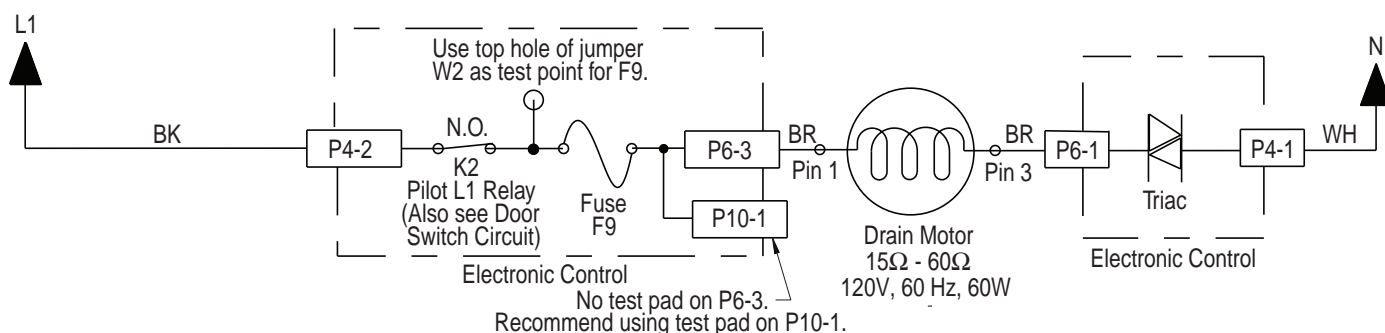

For Service Technician Use Only

⚠ DANGER



Electrical Shock Hazard

Only authorized technicians should perform diagnostic voltage measurements.

After performing voltage measurements, disconnect power before servicing.

Failure to follow these instructions can result in death or electrical shock.

Test Procedure

1. Unplug dishwasher or disconnect power.
2. Remove outer door panel to access control board.
3. Unplug connector P10 from control board.
4. Check the vent wax motor and harness—using an ohmmeter, measure the resistance between P10-1 and P10-3.
 - If the resistance is between 600-1800 ohms, the wax motor and harness are good. Go to step 5.
 - If outside the range, replace the vent wax motor.
 - If an open circuit is detected, check connections and harness continuity between control and vent wax motor. If good, replace the wax motor.
5. Reconnect P10 to control board.
6. Plug in dishwasher or reconnect power.
7. Check for AC voltage from the Control. Start the Diagnostic Cycle and measure for AC out of the control between P10-1 to P10-3 using a voltmeter set to AC.

NOTE: During the Diagnostic Cycle, the vent wax motor is always energized.

 - If no AC voltage is measured, replace the control board and retest.
 - If 120V AC is measured and vent wax motor is energized, go to step 8.
8. Unplug dishwasher or disconnect power.
9. Reassemble all parts and panels.
10. Plug in dishwasher or reconnect power.

Vent Wax Motor (not on all models)

This test will check the wiring to the vent and the vent wax motor itself. The following items are part of the vent wax motor circuit.

- Harness/Connection
- Vent Wax Motor
- Control Board

NOTES:

Only dishwashers with the Heated Dry option have a vent and fan. If moisture is detected between outer and inner door panels or on cabinets around air inlet located on side of door panel, check that the vent damper is closing properly using the Service Diagnostic Cycle.

Also verify that wax motor seal and vent bezel seal are not pinched or missing. Verify there are no leaks around the vent bezel seal allowing moisture past the bezel and into the door panel area.

Strip Circuit – Vent Wax Motor

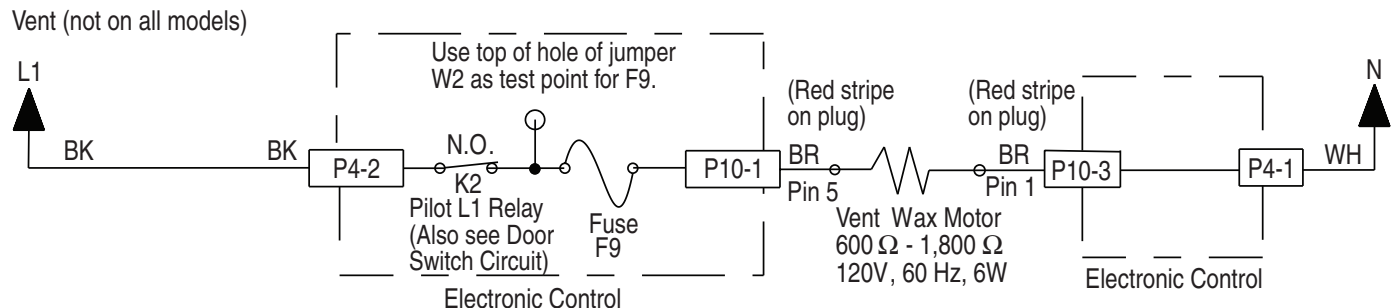

For Service Technician Use Only

⚠ DANGER



Electrical Shock Hazard

Only authorized technicians should perform diagnostic voltage measurements.

After performing voltage measurements, disconnect power before servicing.

Failure to follow these instructions can result in death or electrical shock.

Vent Fan (not on all models)

This test will check the wiring to the vent and the vent fan itself. The following items are part of the vent fan circuit.

- Harness/Connection
- Vent Fan
- Control Board

NOTES:

Only dishwashers with the Heated Dry option have a vent and fan. If moisture is detected between outer and inner door panels or on cabinets around air inlet located on side of door panel, check that the vent damper is closing properly using the Service Diagnostic Cycle.

Also verify that wax motor seal and vent bezel seal are not pinched or missing. Verify there are no leaks around the vent bezel seal allowing moisture past the bezel and into the door panel area.

Test Procedure

1. Check the vent fan and electrical connections by performing the Service Diagnostic Cycle. The following steps assume that this step was unsuccessful.
2. Unplug dishwasher or disconnect power.
3. Remove outer door panel to access control board.
4. Unplug connector P10 from control board.
5. Check the resistance of the fan motor coil. With a ohmmeter, connect the black lead to P10-5 and the red lead to P10-4. **IMPORTANT:** Note measurement polarity.
 - If the resistance is between 31-41 k-ohms, the fan motor and harness are good. Go to step 6.
 - If outside the range, replace the fan motor.
 - If an open circuit is detected, check connections and harness continuity between control and fan motor. If good, replace the fan motor assembly.
6. Reconnect P10 to control board.
7. With a voltmeter set to DC, connect the black lead to P10-6 and the red lead to P10-5. **IMPORTANT:** Note measurement polarity.
8. Plug in dishwasher or reconnect power.
9. Check for DC voltage from the Control. Start the Diagnostic Cycle and at the proper interval measure for +5V DC out of the control between P10 pins 4 & 5.
 - If +5V DC is measured and fan is running, go to step 10.
 - If no voltage is measured, replace the control board and retest.
10. Unplug dishwasher or disconnect power.
11. Reassemble all parts and panels.
12. Plug in dishwasher or reconnect power.

Strip Circuit – Vent Fan

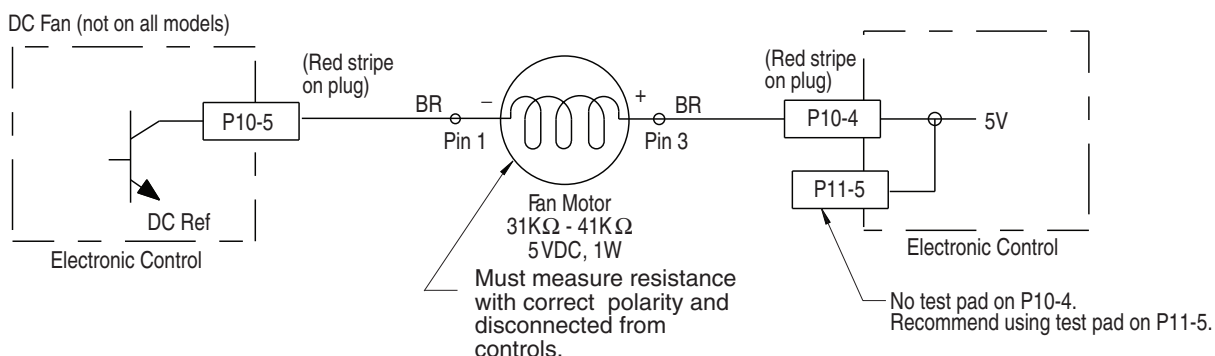

For Service Technician Use Only

⚠ DANGER



Electrical Shock Hazard

Only authorized technicians should perform diagnostic voltage measurements.

After performing voltage measurements, disconnect power before servicing.

Failure to follow these instructions can result in death or electrical shock.

6. Check the fan motor—using an ohmmeter, measure the resistance between P7-1 and P7-3.
 - If the resistance is between 60-80 ohms, the fan motor and harness are good. Go to step 7.
 - If outside the range, replace the fan motor assembly.
 - If an open circuit is detected, check connections and harness continuity between control and fan motor. If good, replace the fan motor assembly.
7. Reconnect P7 to control board.
8. Set voltmeter to AC and connect leads to test-pads P10-1 & P7-1 on the control board. Plug in dishwasher or reconnect power.
9. Start the Diagnostic Cycle and at the proper interval measure for AC out of the control between P10-1 & P7-1. (Refer to AC Fan Motor Strip Circuit below.)

IMPORTANT: The Fan Motor must be connected to the control board to measure voltage accurately!!!

 - If no AC voltage is measured, replace the control board and retest.
 - If 120 VAC is measured and the fan is spinning, go to step 10.
10. Unplug dishwasher or disconnect power.
11. Reassemble all parts and panels.
12. Plug in dishwasher or reconnect power and run Diagnostic Cycle to verify repair.

AC Fan Motor (not on all models)

This test will check the wiring to the AC fan motor and the fan motor itself. The following items are part of the AC Fan Motor circuit.

- Harness/Connection
- AC Fan Motor
- Control Board

Test Procedure

1. Check for fan operation in the Diagnostic Cycle. The AC fan should be running during cycles 19, 16, 15, and 3.
2. Are all the loads controlled by TRIACs **not** working?
 - YES – check for open door switch, TRIAC fuse, or pilot relay.
 - NO – just the diverter valve. Go to step 3.
3. Unplug dishwasher or disconnect power.
4. Remove outer door panel to access control board.
5. Unplug connector P7 from control board.

Strip Circuit – AC Fan Motor

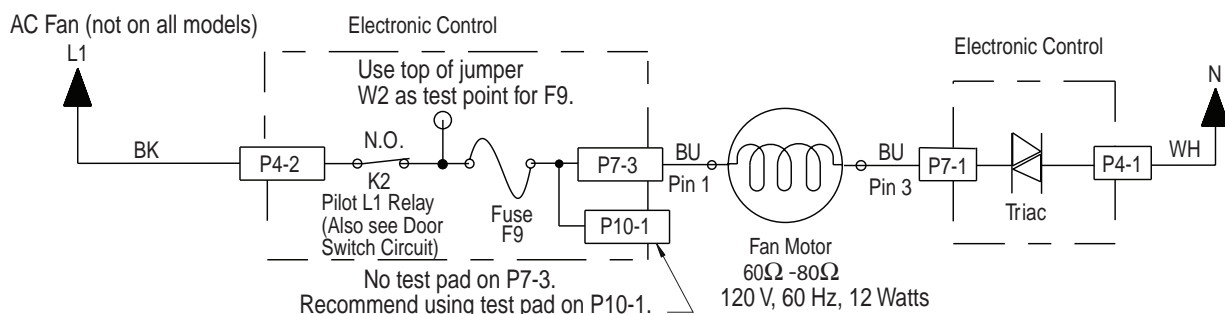

For Service Technician Use Only

⚠ DANGER



Electrical Shock Hazard

Only authorized technicians should perform diagnostic voltage measurements.

After performing voltage measurements, disconnect power before servicing.

Failure to follow these instructions can result in death or electrical shock.

Power Blast (not on all models)

This test will check the wiring to the Power Blast and the Power Blast wax motor itself. The following items are part of the Power Blast wax motor circuit.

- Harness/Connection
- Power Blast Wax Motor
- Control Board

Test Procedure

1. Unplug dishwasher or disconnect power.
2. Remove outer door panel to access control board.
3. Unplug connector P7 from control board.
4. Check the Power Blast wax motor and harness—using an ohmmeter, measure the resistance between P7-4 and P7-6.
 - If the resistance is between 600-1800 ohms, the wax motor and harness are good. Go to step 5.
 - If outside the range, replace the Power Blast wax motor.
 - If an open circuit is detected, check connections and harness continuity between control and Power Blast wax motor. If good, replace the wax motor.
5. Reconnect P7 to control board.
6. Plug in dishwasher or reconnect power.
7. Check for AC voltage from the Control. Start the Diagnostic Cycle and at the proper interval measure for AC out of the control between P7-4 to P7-6 using a voltmeter set to AC.
 - If no AC voltage is measured, replace the control board and retest.
 - If 120V AC is measured and Power Blast wax motor is energized, go to step 8.
8. Unplug dishwasher or disconnect power.
9. Reassemble all parts and panels.
10. Plug in dishwasher or reconnect power.

Strip Circuit – Power Blast

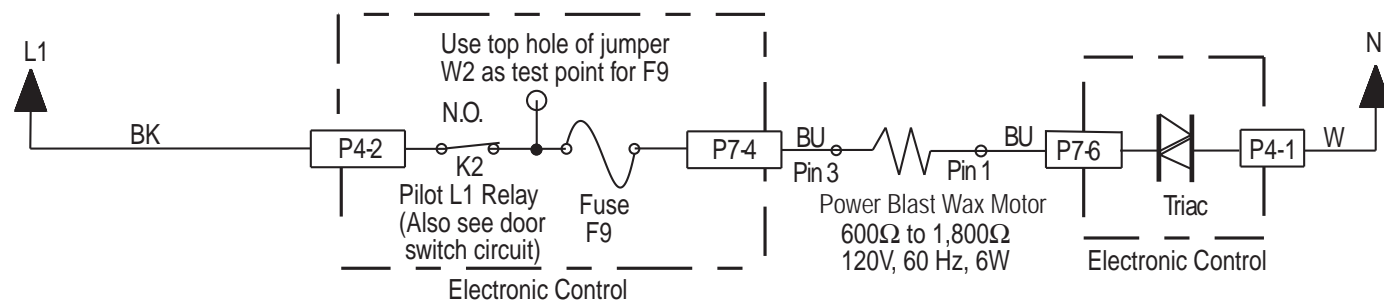

For Service Technician Use Only

⚠ DANGER



Electrical Shock Hazard

Only authorized technicians should perform diagnostic voltage measurements.

After performing voltage measurements, disconnect power before servicing.

Failure to follow these instructions can result in death or electrical shock.

User Interface (UI)

This test will check the wiring to the user interface and the user interface itself. The following items are part of the user interface circuit.

- Harness/Connection
- User Interface (UI)
- Status LED (On some models)
- Control Board

Test Procedure

1. Verify that the control lock-out feature has not been turned on by the customer. If unit will not run or power up, perform Power Check procedure on page 3-6. Also, check for excessive condensation on UI parts due to vent and/or fan problem.
2. Unplug dishwasher or disconnect power.
3. Remove outer door panel to access control board.
4. Disconnect user interface connection from control board. Verify all other connections to the control are good.
5. Open dishwasher door.
6. Plug in dishwasher or reconnect power.
7. Wait at least 7 seconds for control to power-up completely.
8. Close dishwasher door and monitor control response:
 - If control is OK, it will respond by turning on the drain motor for 2 minutes. Replace user interface assembly.
 - If control is not OK, it will **not** turn on the drain motor. Wait for at least 10 seconds. If still no drain response, then replace control or LCD display module (whichever one the UI was connected to).
9. Unplug dishwasher or disconnect power.
10. Reassemble all parts and panels.
11. Plug in dishwasher or reconnect power.

Section 4: Component Access

This section provides service parts access, removal, and installation instructions for the “Maytag Chopper Dishwashers.”

- Door Spring Adjustment
- Installing Insulation Blanket
- Removing Door Latch Strike
- Accessing Door Components & User Interface
- Removing Door Latch Assembly
- Removing Electronic Control Board
- Removing the Dispenser
- Removing the Water Fill & Drain Components
- Advanced Power Dry™ (Side Dry)
- Overfill Assembly
- In Tub Components
- Spray Arms, Feed Tube, and Manifold
- Removing the Racks
- Removing the Lower Spray Arm
- Under Tub Components
- Removing Heater Assembly
- Removing the Drain Pump
- Removing the Optical Water Indicator
- Removing the Sump Assembly
- Chopper Motor Assembly Parts
- Removing the Chopper Motor Assembly

Adjustable Door Springs

⚠ WARNING



Electrical Shock Hazard
Disconnect power before servicing.
Replace all parts and panels before operating.
Failure to do so can result in death or electrical shock.

Door Spring Adjustment

1. Unplug dishwasher or disconnect power.
2. Remove the dishwasher from the installation.
3. With another person holding the dishwasher to keep it from tipping, open and close the door a few times. If the door closes or falls open under its own weight, the door tension will need to be adjusted. See Figure 1.

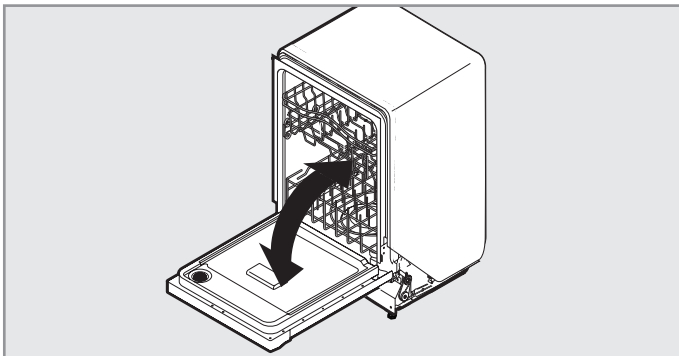

Figure 1

Door Closes Too Quickly

1. To adjust the door spring tension, unhook the spring from the rear leg of dishwasher. See figure 2.
2. Using a 5/16" nut driver or hex socket, remove the screw from the tensioner.
3. The screw can be put into one of 3 holes (1, 2, 3) in the front leg of dishwasher, see figure 2. If the door closes by itself, move the tensioner to a lower-numbered hole and replace screw.
4. Reattach door spring to rear leg.

NOTE: Tensioners on both sides of dishwasher should be secured at same holes.

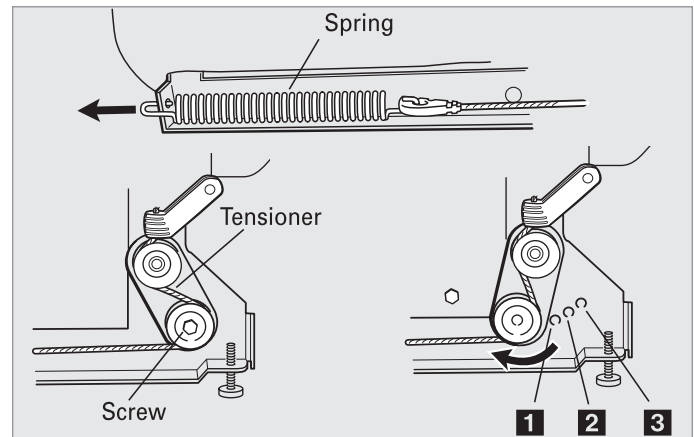

Figure 2

Door Falls Open

1. When door is unlatched, if door opens by itself, move the tensioner to a higher-numbered hole and replace the screw. See Figure 3.
2. Reattach door spring to rear leg.

NOTE: Tensioners on both sides of dishwasher should be secured at same holes.

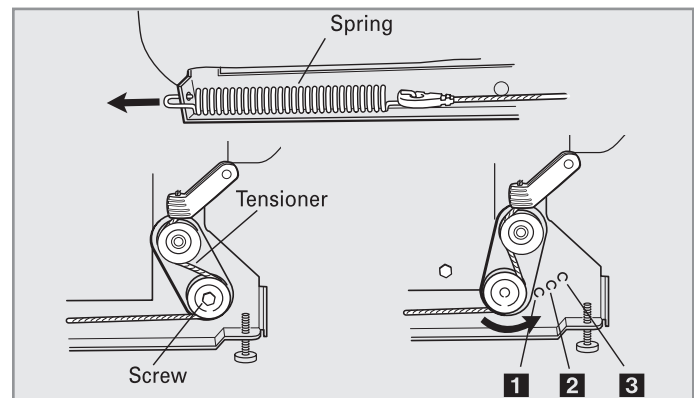

Figure 3

Insulation Blanket and Door Latch Strike

⚠ WARNING



Electrical Shock Hazard
 Disconnect power before servicing.
 Replace all parts and panels before operating.
 Failure to do so can result in death or electrical shock.

Installing Insulation Blanket

(Stainless Steel Tub Models Only)

1. Fasten the blanket on the hooks located on each side of the tub, (see Figures 1 and 2).



Figure 1



Figure 2

Removing Door Latch Strike

1. Open the dishwasher door.
2. Depress the 2 outside bars and pull out the latch, (see Figures 1, 2 and 3).

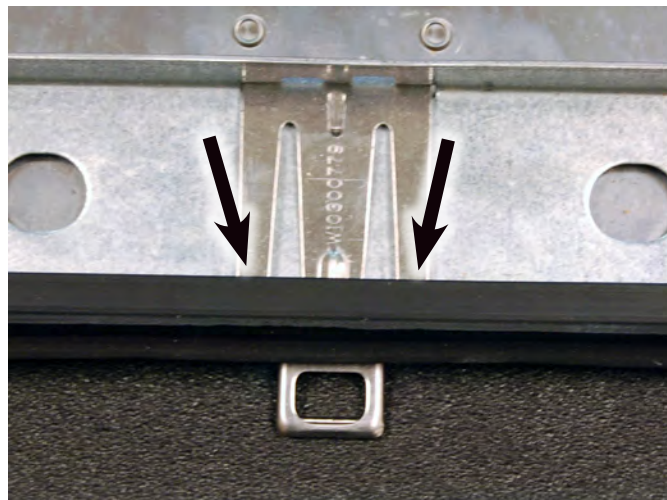

Figure 1

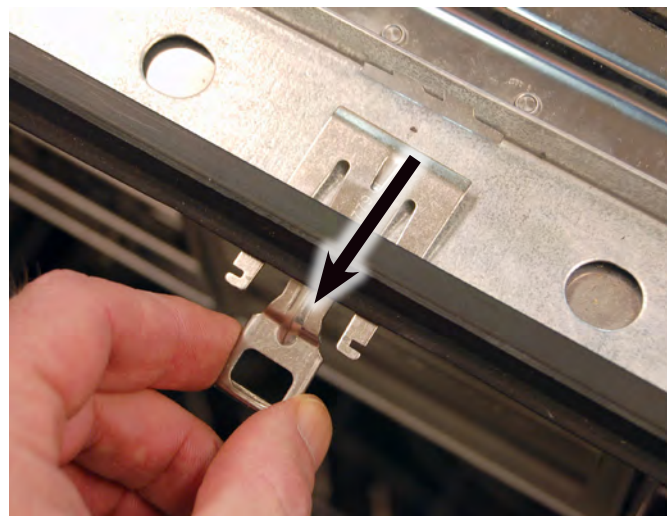



Figure 2



Figure 3

Accessing Door Components & User Interface

⚠ WARNING



Electrical Shock Hazard
 Disconnect power before servicing.
 Replace all parts and panels before operating.
 Failure to do so can result in death or electrical shock.

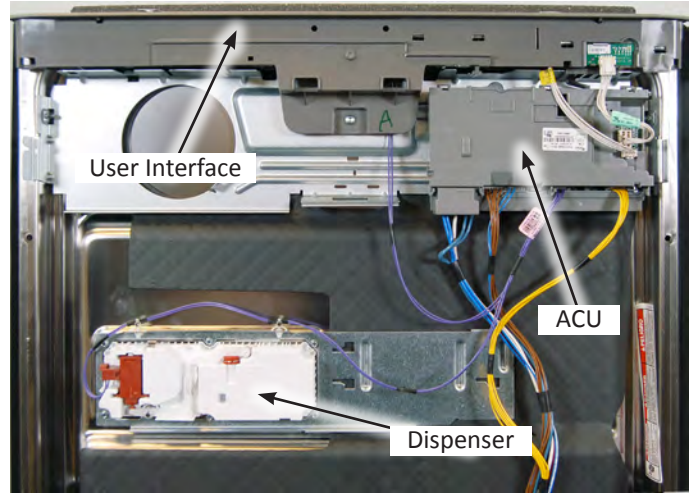

Figure 3 - ACU & UI on Inner Door Panel

Remove Outer Door Panel

1. Unplug dishwasher or disconnect power.
2. Remove ten (10) T-15 screws on the sides and top of door panel assembly (see Figure 1).



Figure 1

3. Move the outer door panel away from door assembly with enough room to disconnect the User Interface and/or ACU harness (depending on model and door panel design). See Figures 2 & 3.

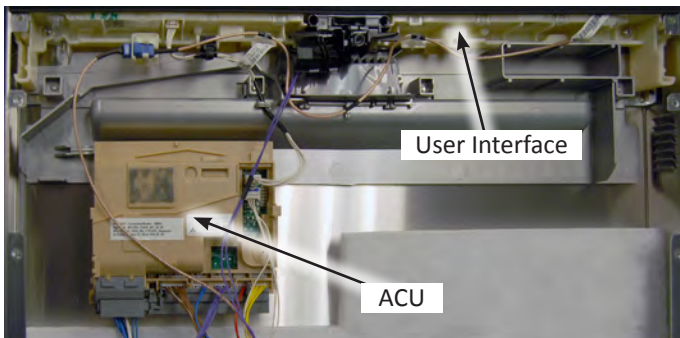

Figure 2 - ACU & UI on Outer Door Panel

4. If necessary, remove the latch assembly from the outer door panel or disconnect the latch assembly harness.
5. Remove the outer door panel assembly.

User Interface Parts

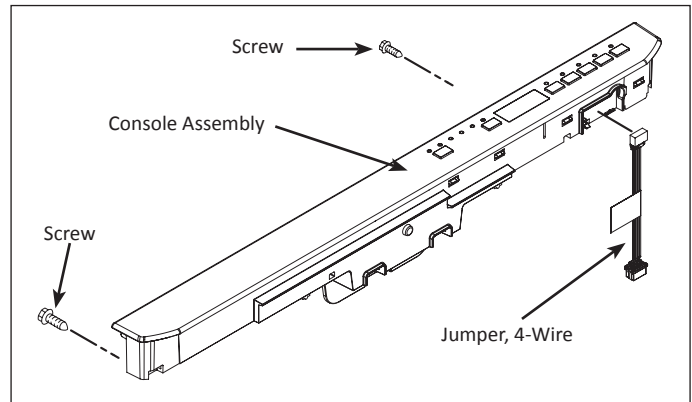

Figure 4 - Towel Bar Doors

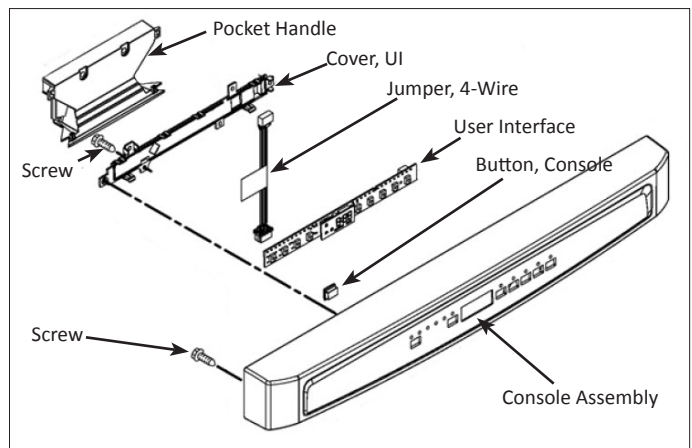



Figure 5 - Pocket Handle Doors

Removing Door Latch Assembly

⚠ WARNING



Electrical Shock Hazard
 Disconnect power before servicing.
 Replace all parts and panels before operating.
 Failure to do so can result in death or electrical shock.

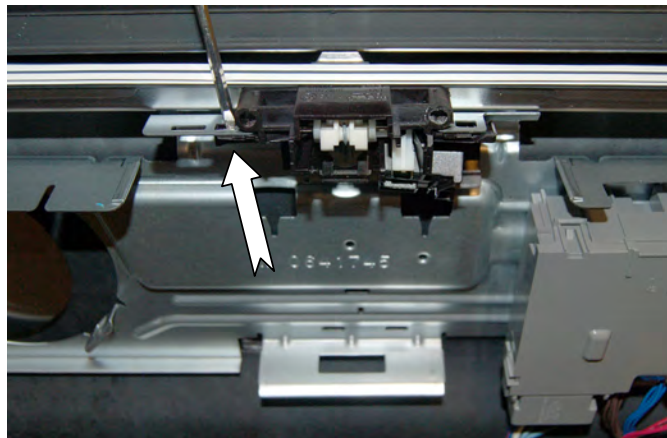

Figure 3

Remove Door Latch Assembly

1. Unplug dishwasher or disconnect power.
2. Perform the procedures on page 4-4, "Remove Outer Door Panel" prior to performing the following steps.
3. On some "early" models, it will be necessary to first remove the UI assembly to access the door latch assembly (see Figure 1).

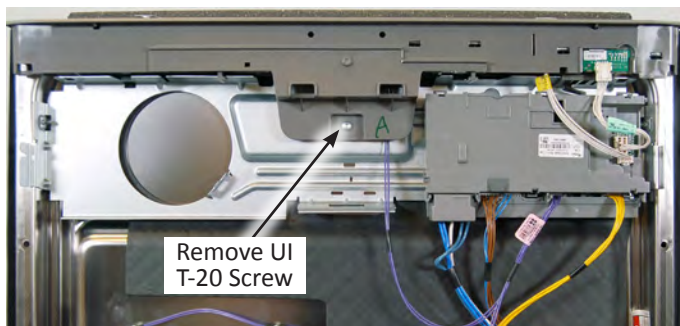

Figure 1

4. To remove door latch assembly, insert a small flat-blade screwdriver into the clip slots on each side of the latch. Gently push in to release latch clips, (see Figures 2 and 3).

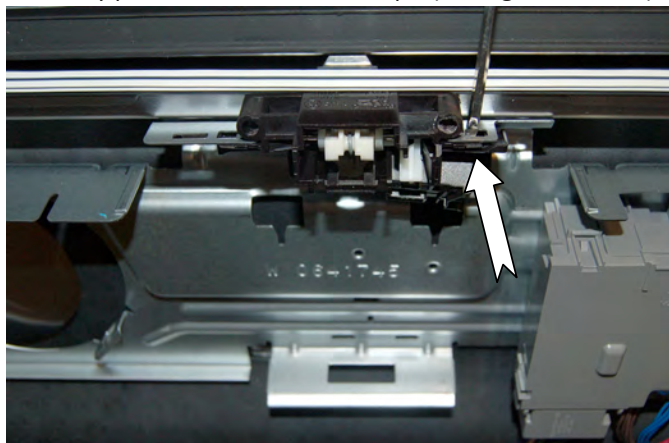

Figure 2

5. Remove latch assembly from door, (see Figure 4).
6. Disconnect harness assembly.

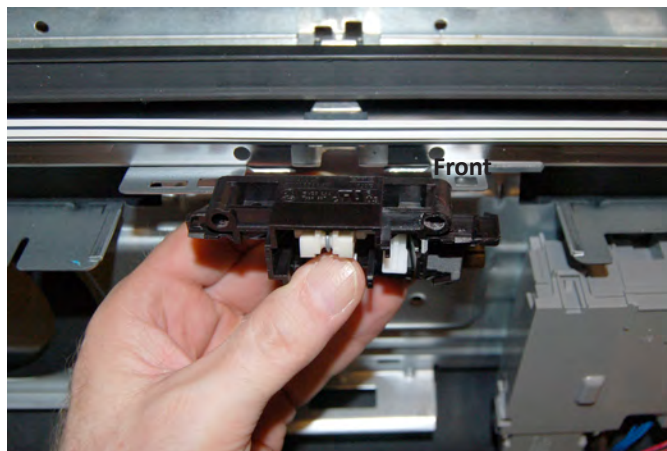

Figure 4

Door Latch

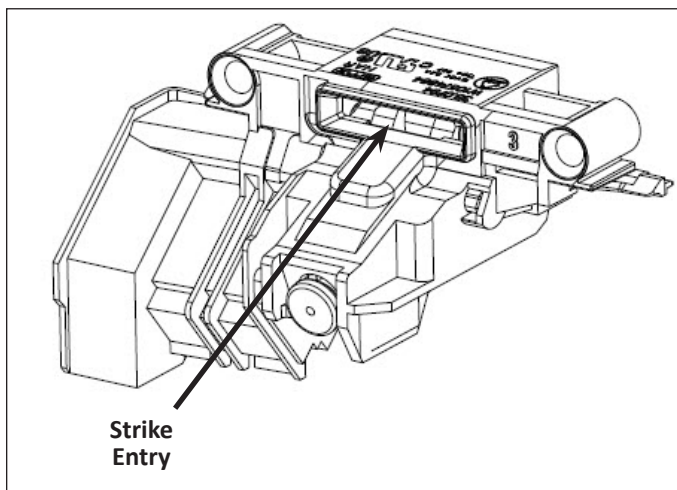



Figure 4

Removing Electronic Control Board

⚠ WARNING



Electrical Shock Hazard
Disconnect power before servicing.
Replace all parts and panels before operating.
Failure to do so can result in death or electrical shock.

Removing the Control (Earlier Models)

1. Unplug dishwasher or disconnect power.
2. Perform the procedures on page 4-4, "Remove Outer Door Panel" prior to performing the following steps.
3. Disconnect harnesses from control board.
4. Depress the locking tab, see Figure 3

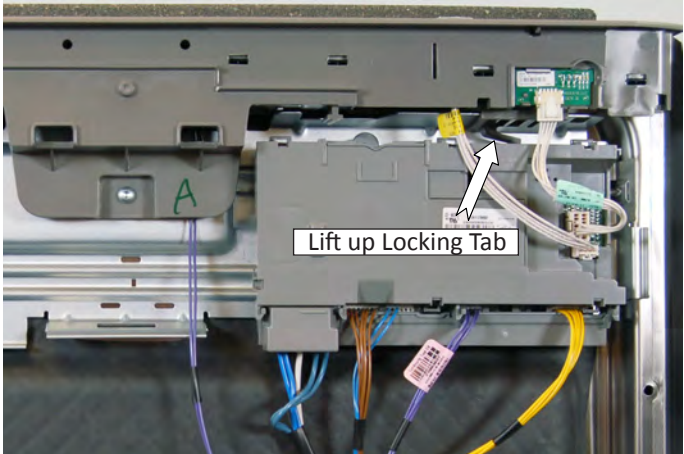

Figure 3 - Lift up Locking Tab

Removing the Control (Later Models)

1. Unplug dishwasher or disconnect power.
2. Perform the procedures on page 4-4, "Remove Outer Door Panel" prior to performing the following steps.
3. Disconnect harnesses from control board.
4. Depress the locking tab, see Figure 1

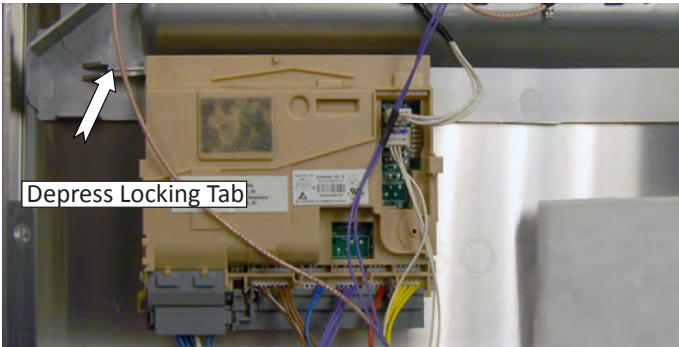

Figure 1 - Depress Locking Tab

4. Slide the electronic control to the left to unhook the tabs on the back of the control from the slots in the door bracket, see Figure 4.

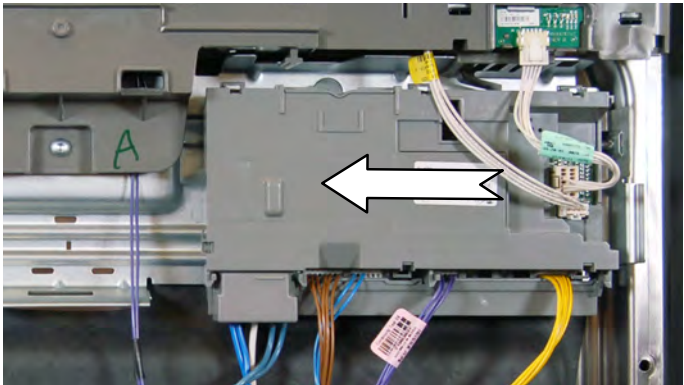

Figure 4 - Slide Control to Left

4. Slide the electronic control to the left to unhook the tabs on the back of the control from the slots in the door bracket, see Figure 2.

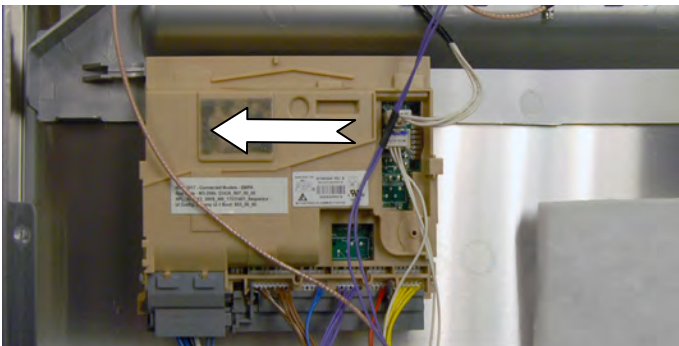

Figure 2 - Slide Control to Left

5. There are two tabs on the back of the control that hook into the slots in the door bracket. See Figure 5.

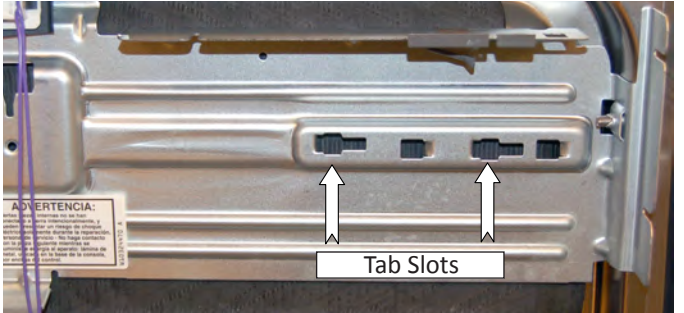

Figure 5 - Control Tab Slots

Removing Dispenser Assembly

⚠ WARNING



Electrical Shock Hazard
 Disconnect power before servicing.
 Replace all parts and panels before operating.
 Failure to do so can result in death or electrical shock.

Removing the Dispenser

1. Unplug dishwasher or disconnect power.
2. Remove the outer panel from the door.
3. Disconnect dispenser harness.
- 4a. **LONG DISPENSER:** Remove - 6 - ¼" hex head screws securing the dispenser to the door. Remove dispenser assembly and bracket, (see Figures 1 & 3).
- 4b. **MINI DISPENSER:** Use a flat-blade screwdriver on locking clips to remove dispenser assembly (see Figures 2 & 4).

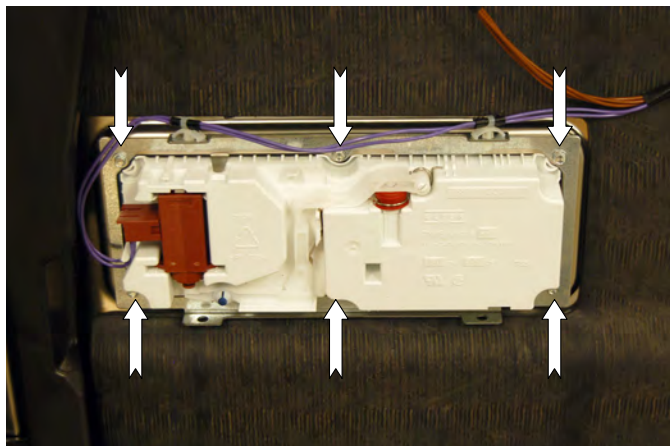

Figure 1 - Long Dispenser

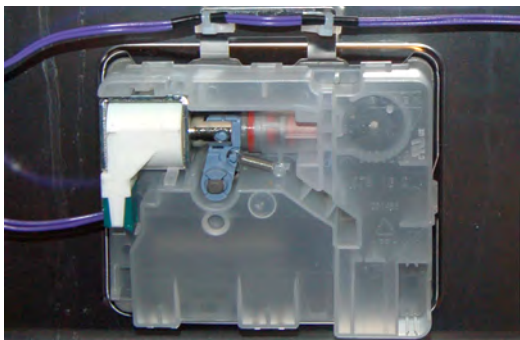

Figure 2 - Mini Dispenser

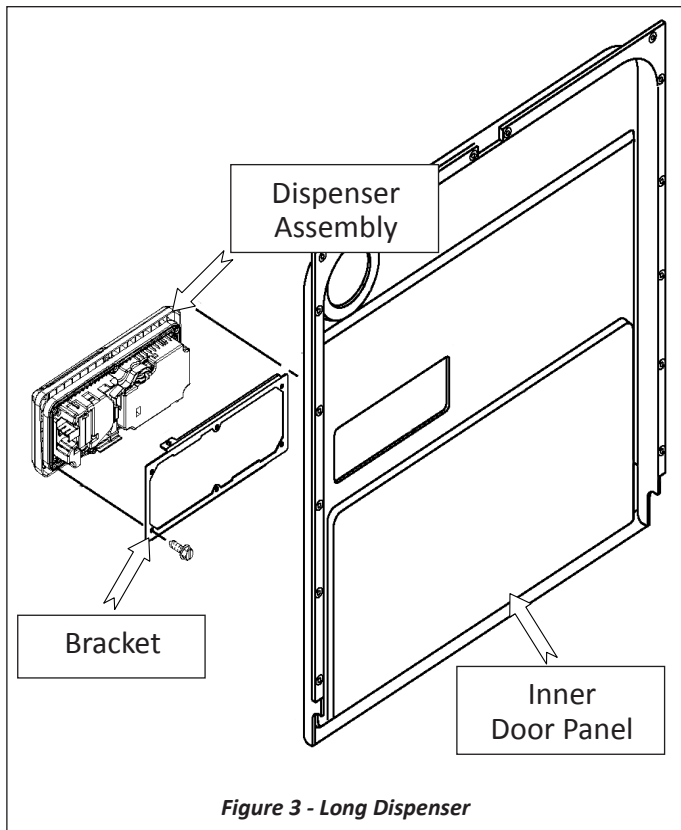

Figure 3 - Long Dispenser

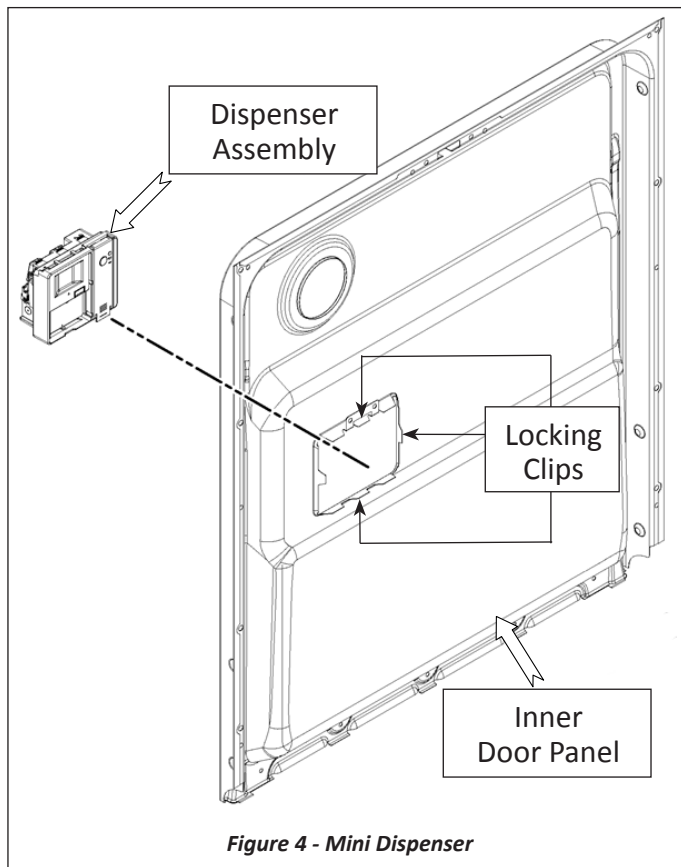

Figure 4 - Mini Dispenser

Removing Water Fill and Drain Components

⚠ WARNING



Electrical Shock Hazard
 Disconnect power before servicing.
 Replace all parts and panels before operating.
 Failure to do so can result in death or electrical shock.

Water Fill & Drain Components (Some Models)

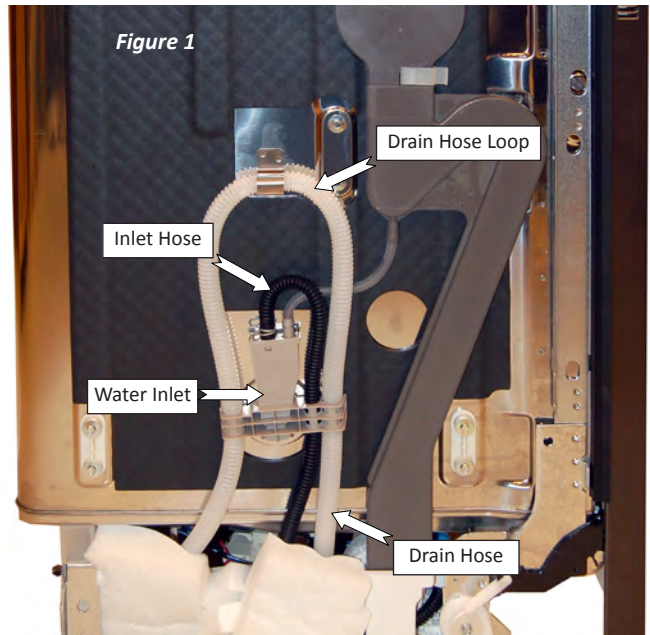

Water Fill & Drain Components (Some Models)

Drain loop must be higher than drain to prevent siphoning. The fill valve and fill hose shown below is the same for Figure 3.

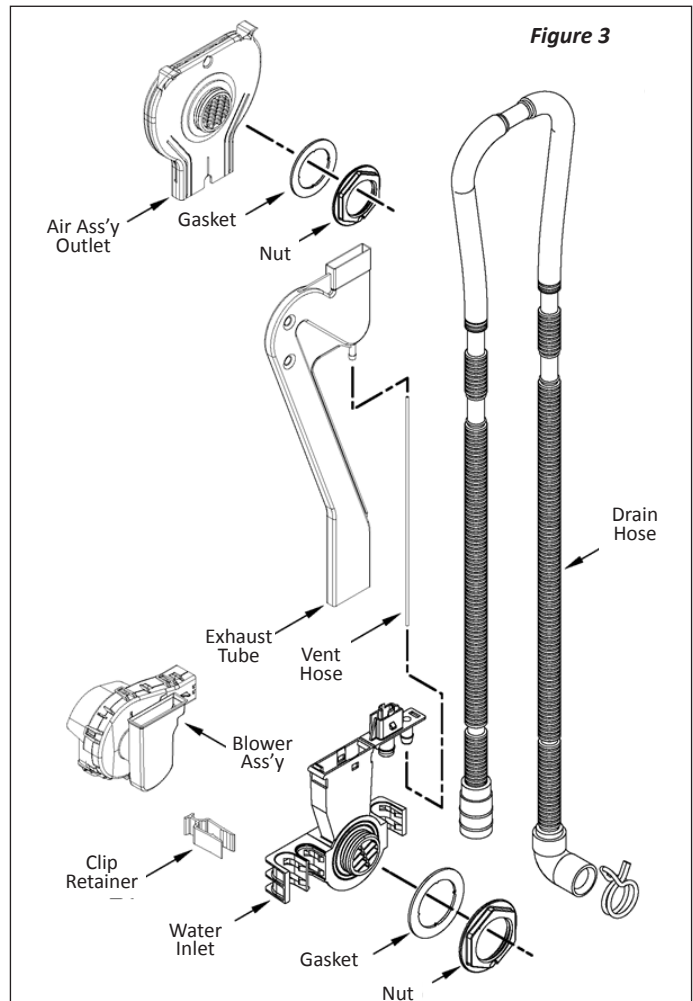
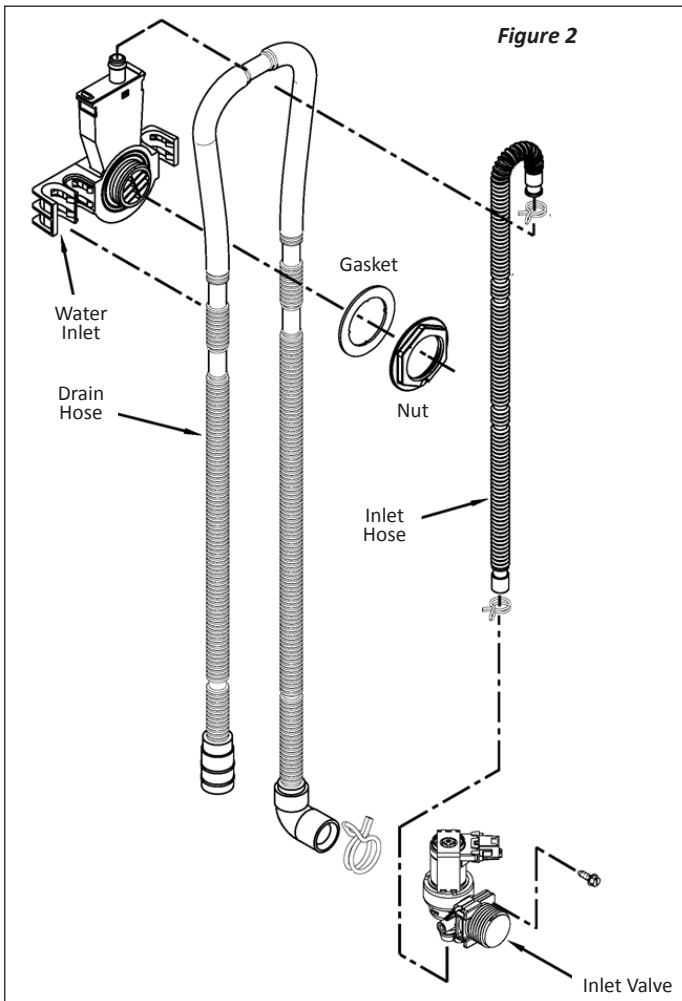

Advanced Power Dry™ (Side Dry)

⚠ WARNING



Electrical Shock Hazard
 Disconnect power before servicing.
 Replace all parts and panels before operating.
 Failure to do so can result in death or electrical shock.

Advanced Power Dry™ Components

1. Unplug dishwasher or disconnect power.
2. Access Power Dry™ components on left side of tub (see Figure 2). To disassemble Power Dry™ components; unscrew air assembly nut from inside tub, disconnect vent hose, then slide exhaust tube and air outlet assembly up and out of blower assembly to remove.

Advanced Power Dry™ Components

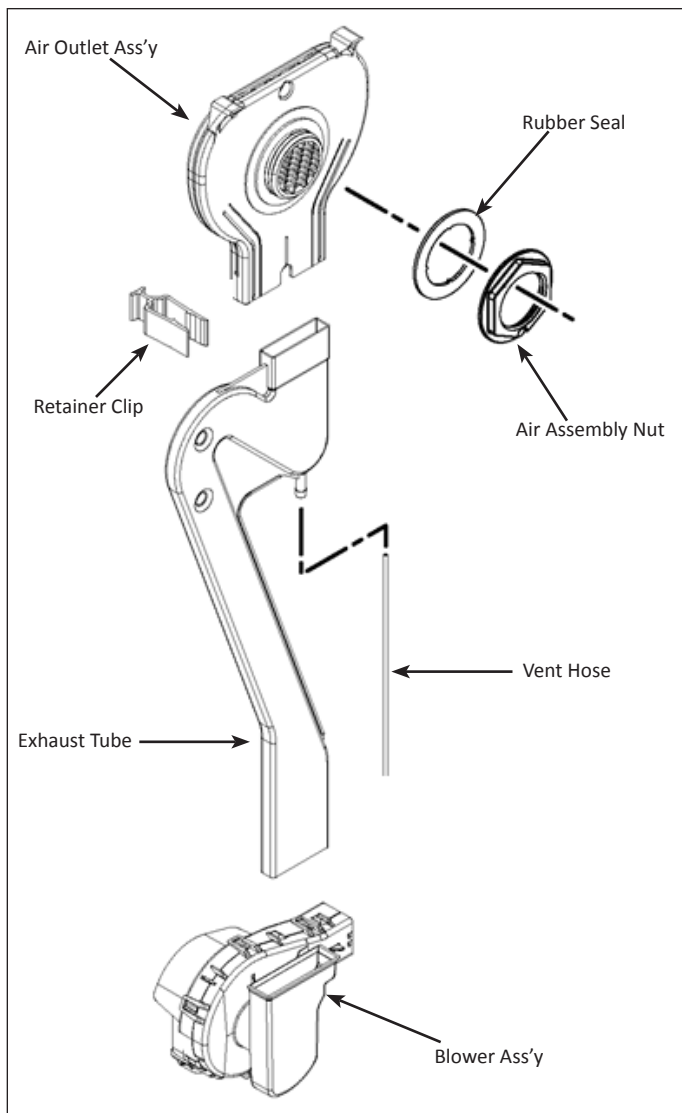

Figure 1

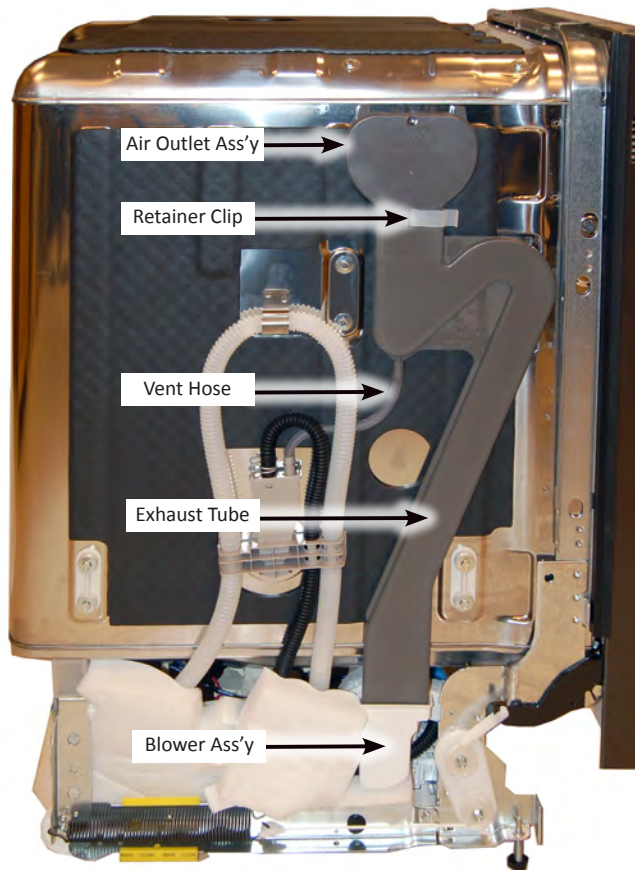

Figure 2

3. From underneath the tub, disconnect the harness and remove the blower vent from the Blower Assembly (see Figure 3).
4. Remove the two (2) 1/4" screws securing Blower Assembly to dishwasher and remove assembly (see Figure 3).

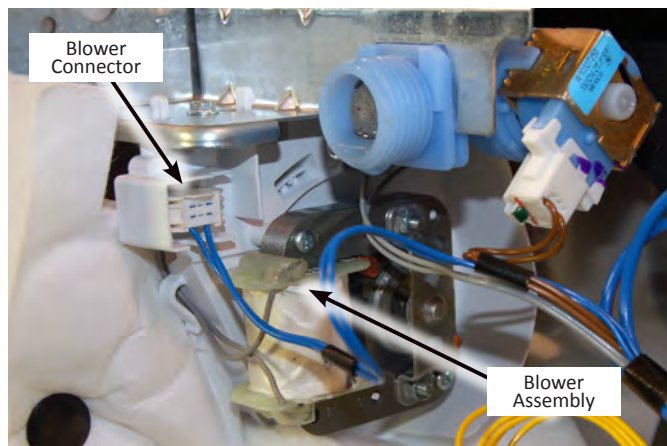



Figure 3

Overfill Assembly

⚠ WARNING



Electrical Shock Hazard
Disconnect power before servicing.
Replace all parts and panels before operating.
Failure to do so can result in death or electrical shock.

Overfill Assembly Components

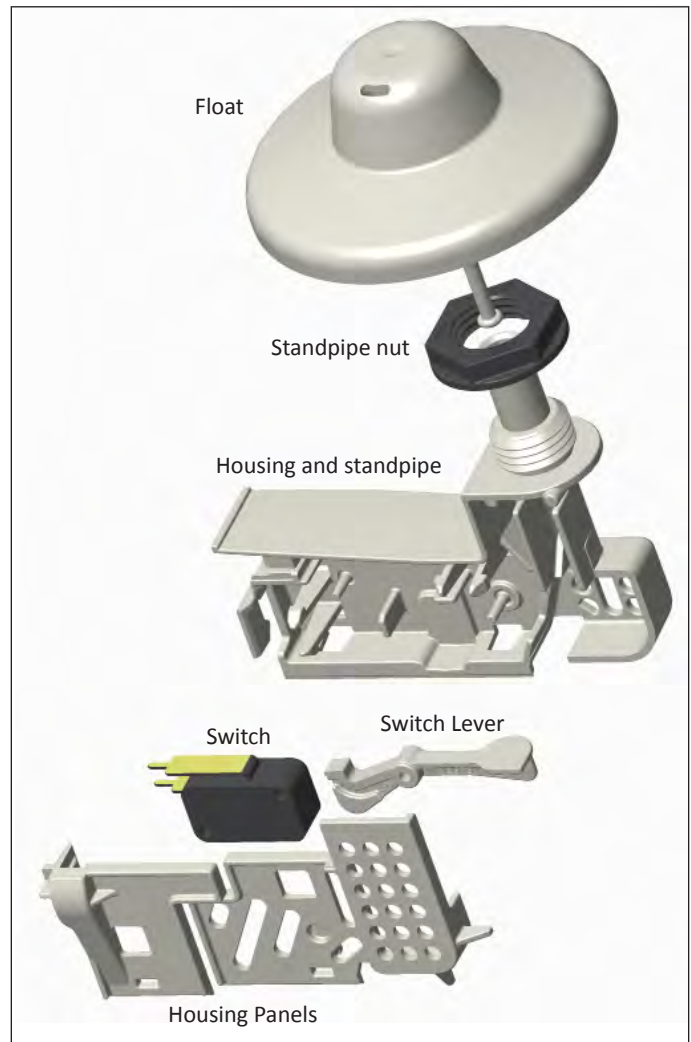

Accessing Overfill Assembly

1. Unplug or disconnect power.
2. Open right and left side covers, (see Figure 1).



Figure 1

Location of float switch components. See Figure 2.

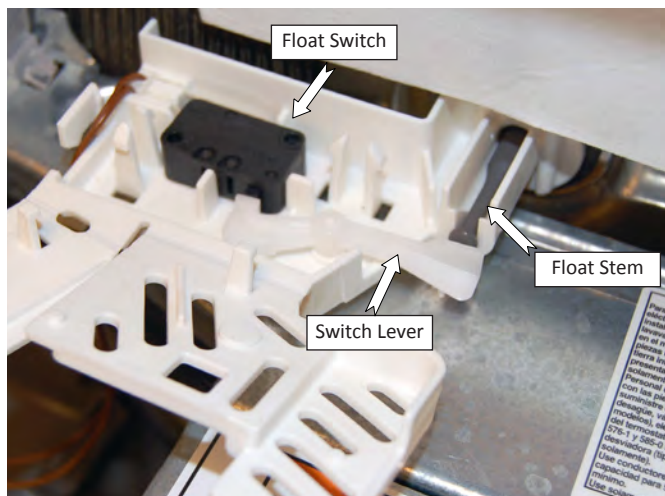
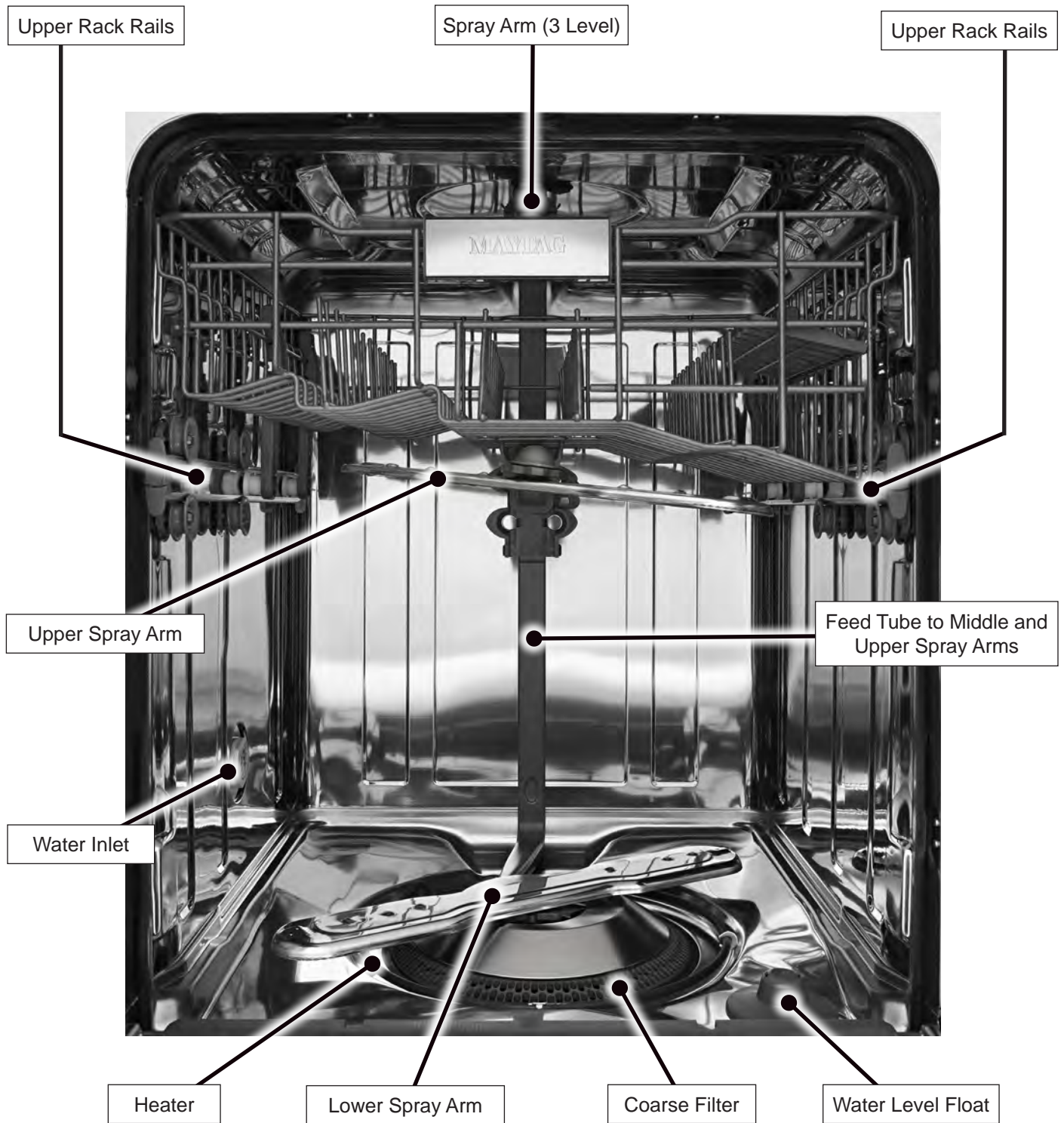

Figure 2

Figure 3

In Tub Components



Tub Component Identification

Spray Arms, Feed Tube, and Manifold

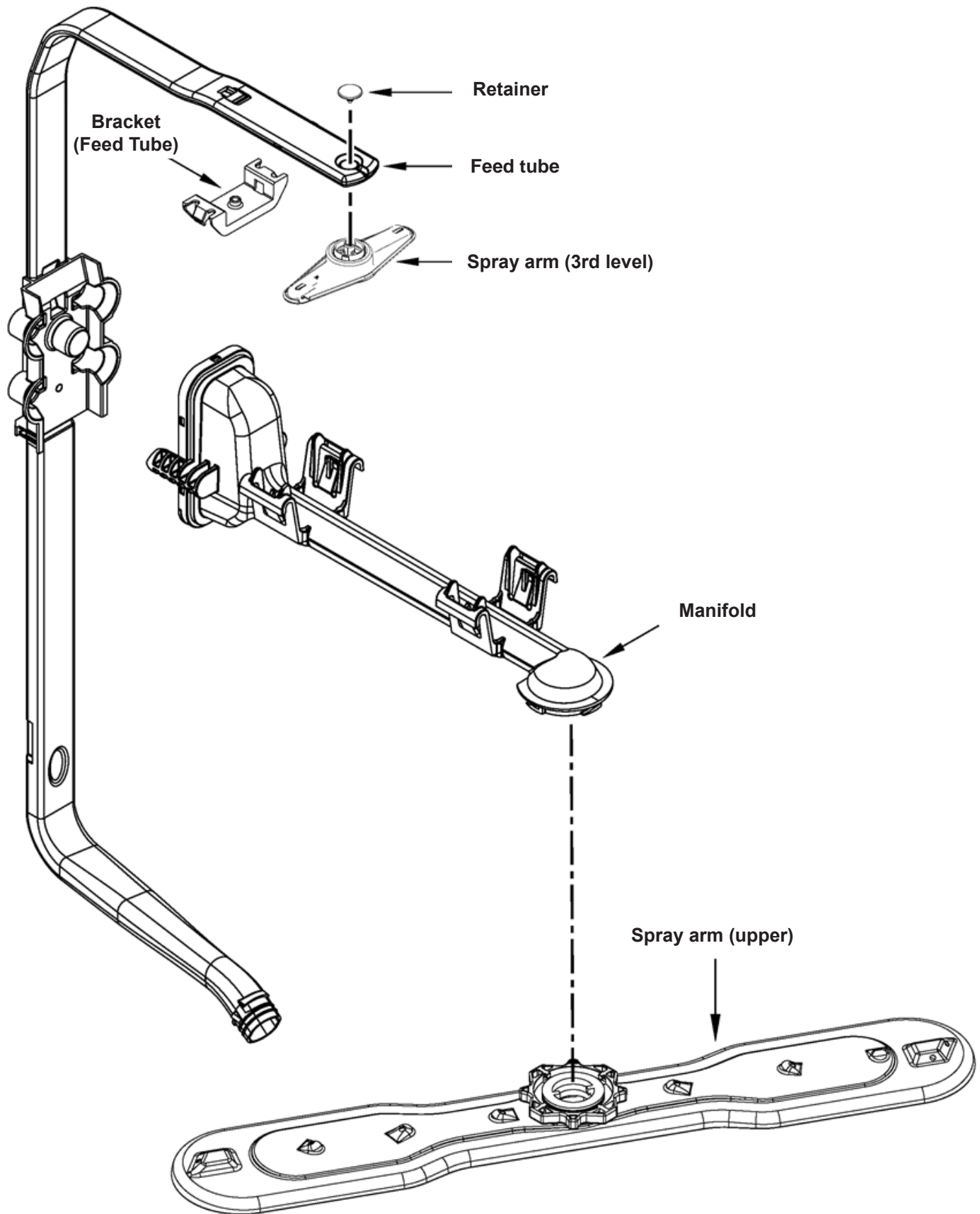

Component Identification

Removing the Racks

Removing The Upper Rack

To Remove the Rack (Lava Rails)

1. To gain access to the removable tabs on the tracks/rails, pull the upper rack forward about halfway out of the tub.
2. On one side, press the tab on the track in and pull up the front end of the rack out of the track. See Figures 1 & 2.

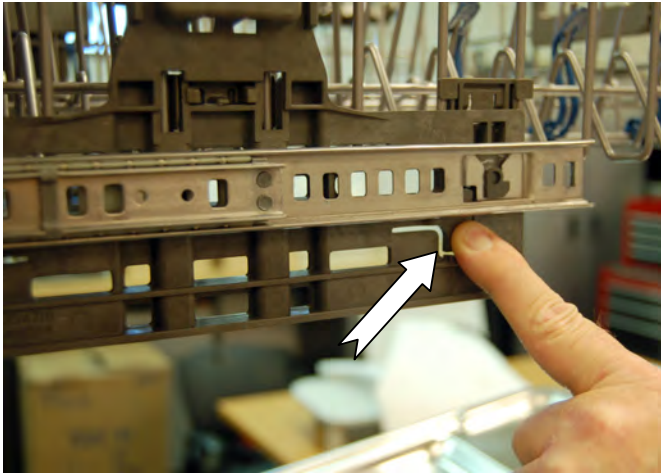

Figure 1

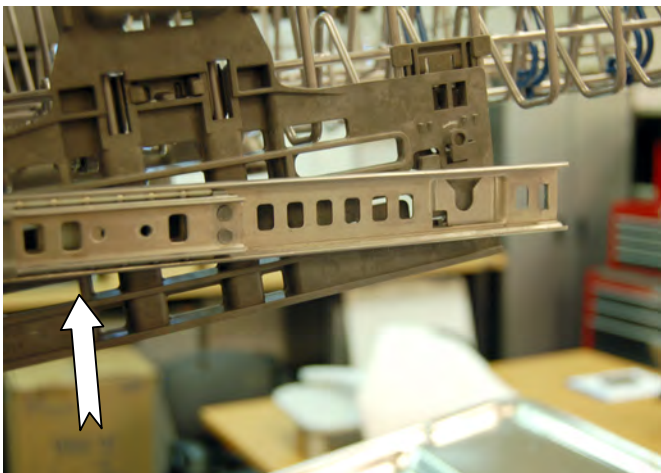

Figure 2

3. Then repeat this step on the other side to completely remove the front end of the rack.
4. Then remove the back end of the rack, by pulling the back end out with a slightly forward, and then upward motion.

To Replace the Rack (Lava Rails)

1. Pull the tracks forward about halfway out of the tub.
2. Along the sides of the racks are round attachment tabs. Align the rack's back end attachment tabs with the cutout in the track. Push down into place.
3. Pull the tracks completely out and align the rack's front end attachment tabs with the cutout in the track. Push down into place. You will hear a snap when the front end of the rack is secured into place on each side.

To Remove the Rack ("C" Rails)

1. Roll the rack 1/3 to 1/2 of the way out of the tub.
2. Rotate the rack stops outward (see Figure 3)
3. Roll the rack all the way out of the track and remove from the dishwasher.



Figure 3

To Replace the Rack ("C" Rails)

1. Reverse the above steps 1-3 to replace the rack into the dishwasher.

Removing the Culinary Tool Rack (3rd level rack - available on some models)

1. Roll the rack 1/3 to 1/2 of the way out of the tub.
2. Rotate the rack stops outward (see Figure 4)
3. Roll the rack all the way out of the track and remove from the dishwasher.

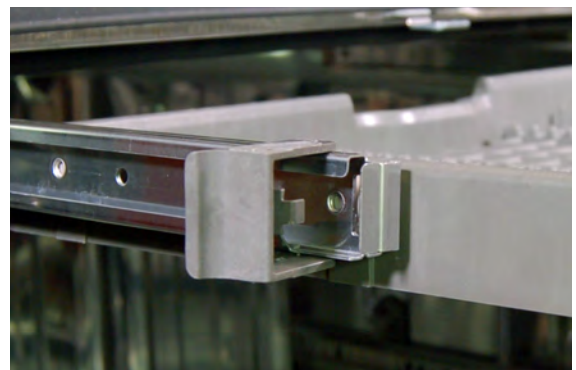

Figure 4

To Replace the Culinary Tool Rack

1. Reverse the above steps 1-3 to replace the rack into the dishwasher.

Removing Lower Spray Arm

To remove the lower spray arm:

1. Lower spray arm nut location, (see Figure 1).

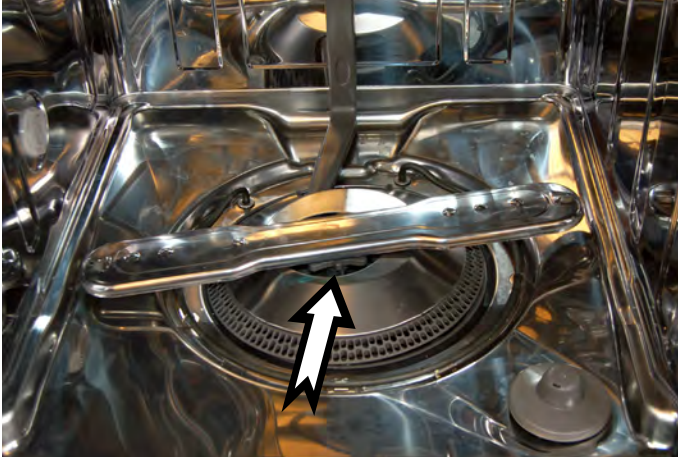

Figure 1

2. Rotate the lower spray arm nut $\frac{1}{4}$ turn counter clockwise to remove the spray arm, (see Figure 2).



Figure 2

3. Lift off lower spray arm, (see Figure 3).

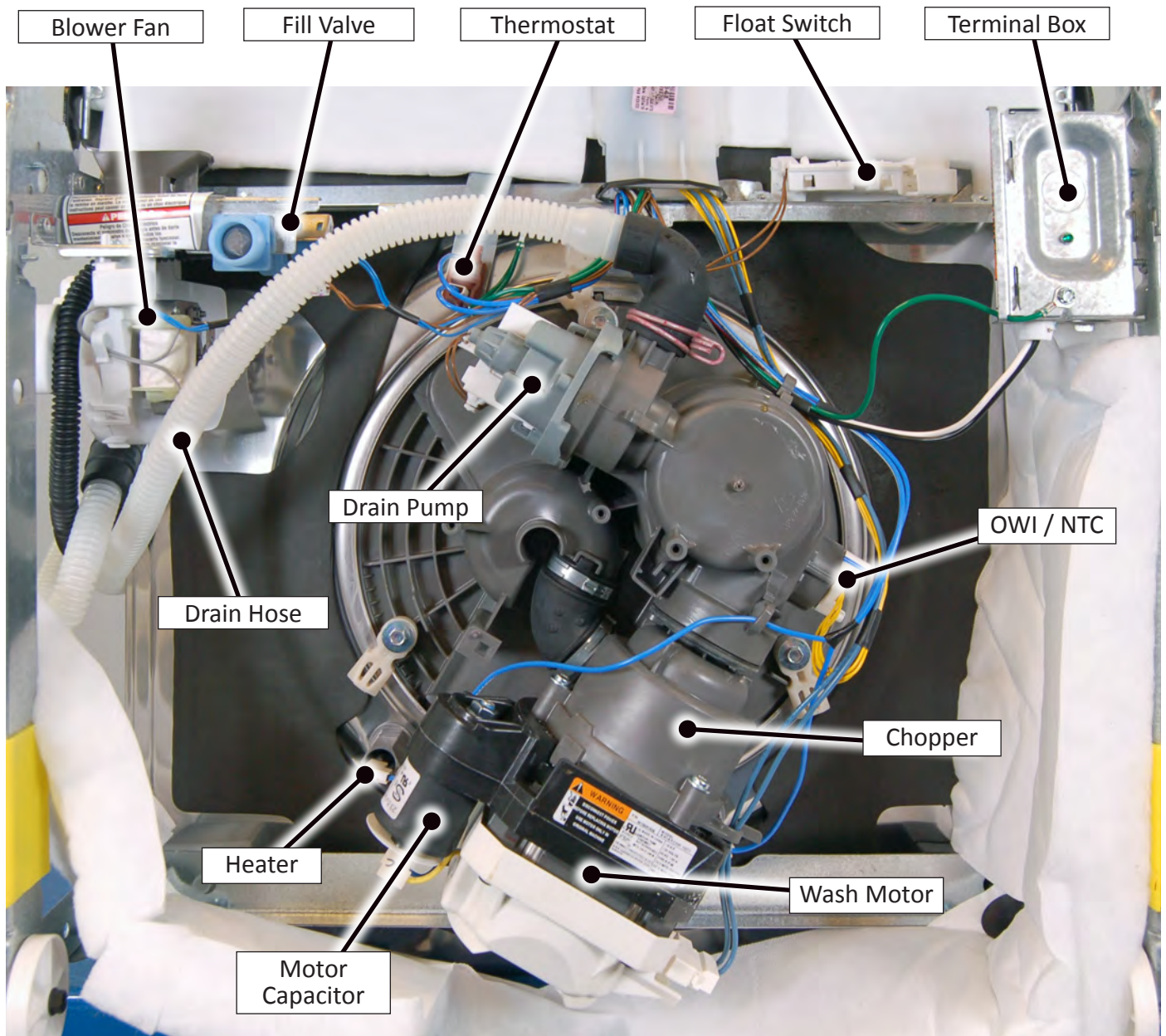

Figure 3

Lower Spray Arm Reinstallation

1. Place spray arm on the diverter housing and slowly turn spray arm until it seats on diverter.
2. Grasp lower spray arm nut and turn $\frac{1}{4}$ " clockwise to secure in place on diverter housing.
3. Run the Diagnostic Cycle to verify spray arm operation.

Under Tub Components



Under Tub Component Identification

Removing Heater Assembly

⚠ WARNING



Electrical Shock Hazard
Disconnect power before servicing.
Replace all parts and panels before operating.
Failure to do so can result in death or electrical shock.

Removing the Heater Assembly

1. Unplug dishwasher or disconnect power.
2. Disconnect wires from both heater terminals (see Figure 1).
3. Remove both heater element nuts (see Figure 2).
4. Remove heater element assembly from tub.

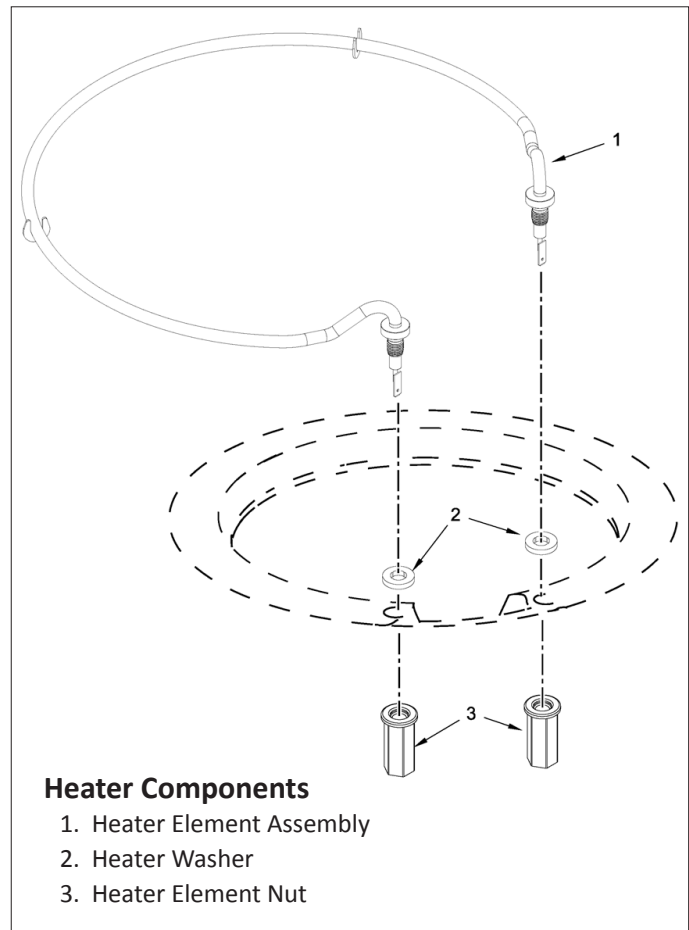

Figure 2

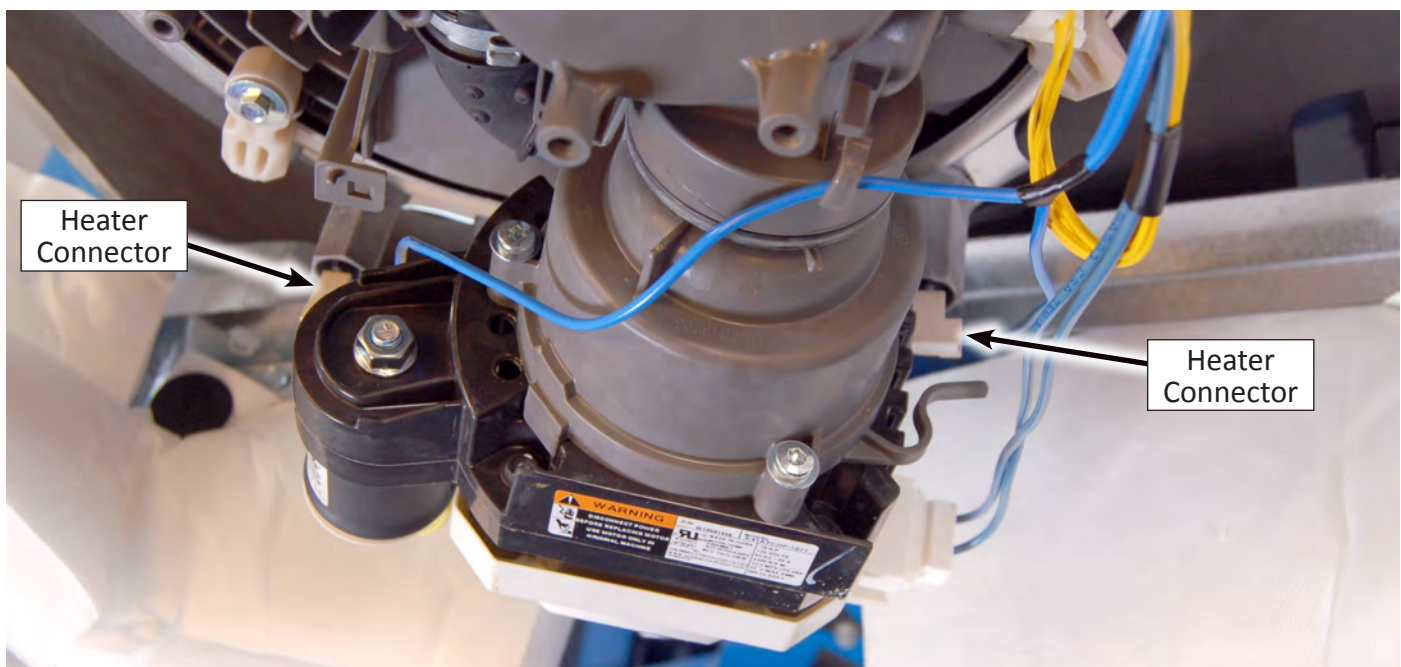

Figure 1

Removing Drain Pump

⚠ WARNING



Electrical Shock Hazard
 Disconnect power before servicing.
 Replace all parts and panels before operating.
 Failure to do so can result in death or electrical shock.

Remove Drain Pump

1. Unplug dishwasher or disconnect power.
2. Release hose clamp and pull off the hose, (see Figure 1).
NOTE: Be prepared to catch the water from the sump area.



Figure 1

3. Unplug the wire harness connected to the drain pump, (see Figure 2).

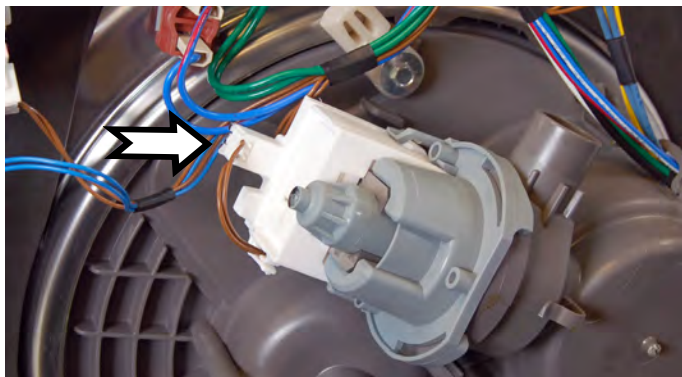

Figure 2

4. Rotate the drain pump 1/4 turn counterclockwise, (see Figure 3).

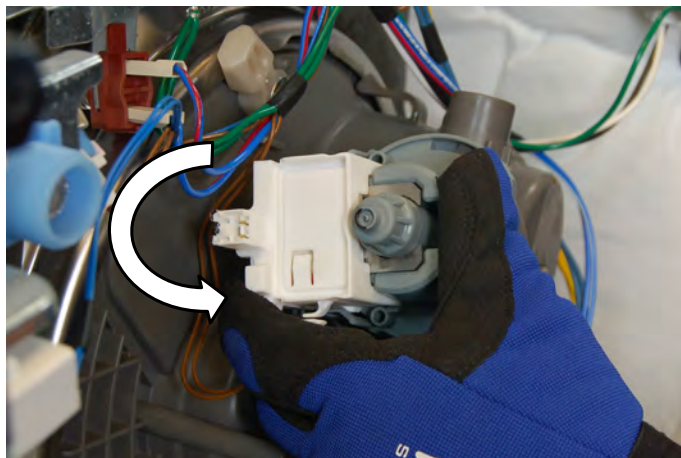

Figure 3

5. Remove the drain pump from sump assembly, (see Figure 4).

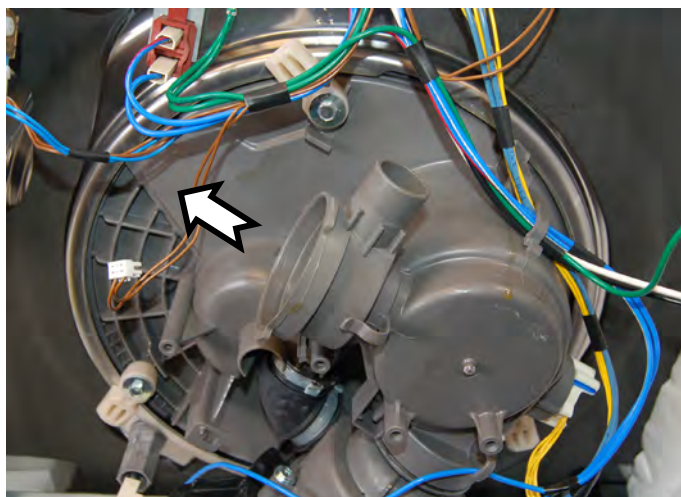

Figure 4

Removing Optical Water Indicator (OWI)

⚠ WARNING



Electrical Shock Hazard
Disconnect power before servicing.
Replace all parts and panels before operating.
Failure to do so can result in death or electrical shock.

Removing Optical Water Indicator

NOTE: The Optical Water Indicator (OWI) can be accessed from the front by removing the toe panel.

1. Unplug dishwasher or disconnect power.
2. Remove the toe panel and attached insulation at the bottom of the dishwasher.
2. Locate OWI on bottom, right-side of sump assembly (see Figure 1).
3. Reach in and rotate the OWI counter-clockwise 1/4 turn.
4. Remove the OWI from sump assembly.
5. Disconnect harness from Optical Water Indicator.

FRONT OF DISHWASHER

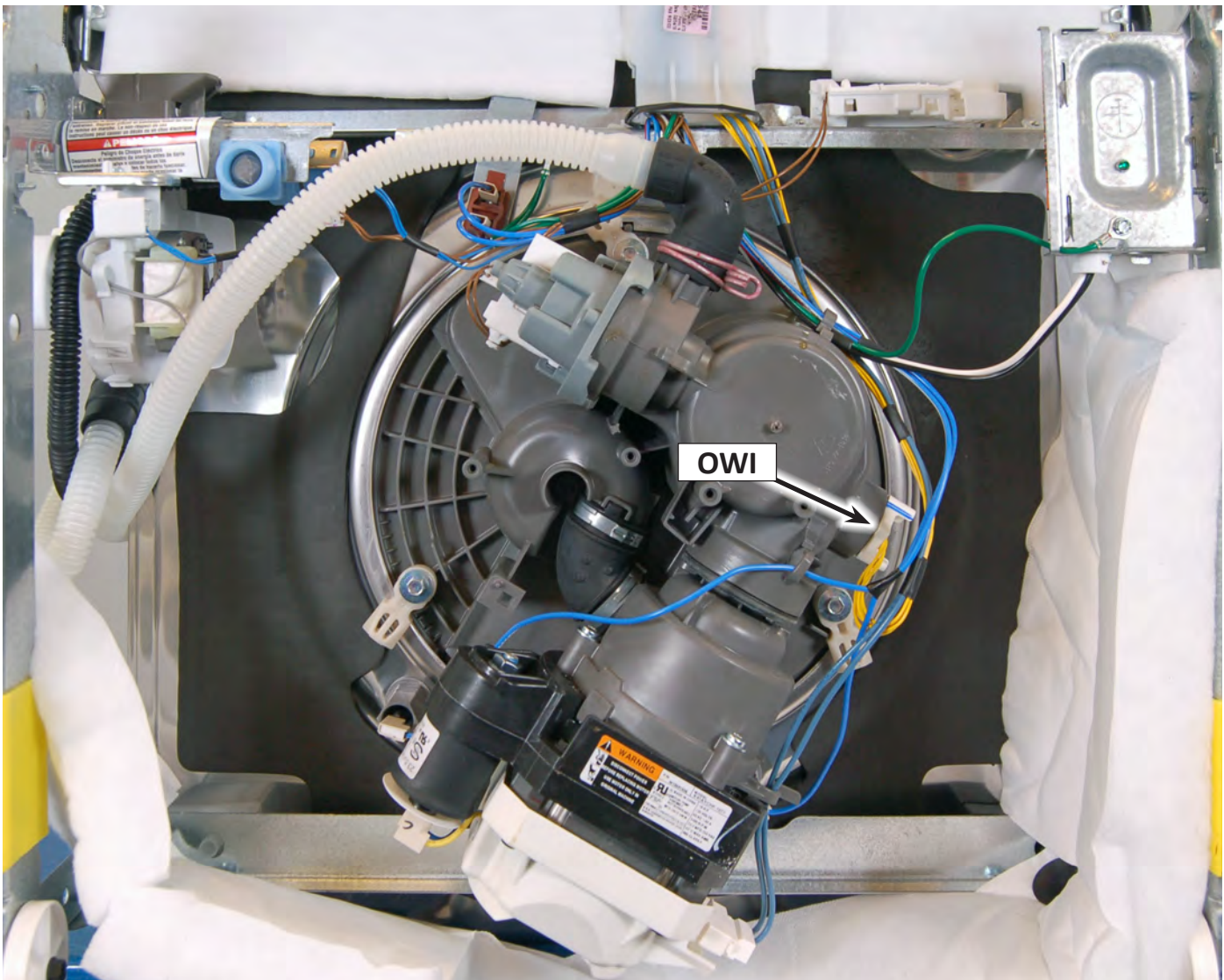

Figure 1

Removing the Sump Assembly

⚠ WARNING



Electrical Shock Hazard
Disconnect power before servicing.
Replace all parts and panels before operating.
Failure to do so can result in death or electrical shock.

Removing the Sump Assembly

Preparation:

Remove the following items from inside the dishwasher (see Figure 1 below):

1. Lower Rack
2. Lower Spray Arm
3. Accumulator Cover
4. Disconnect Feed Tube from Sump
5. Accumulator/Screen Assembly
6. Remove Chopper Protector

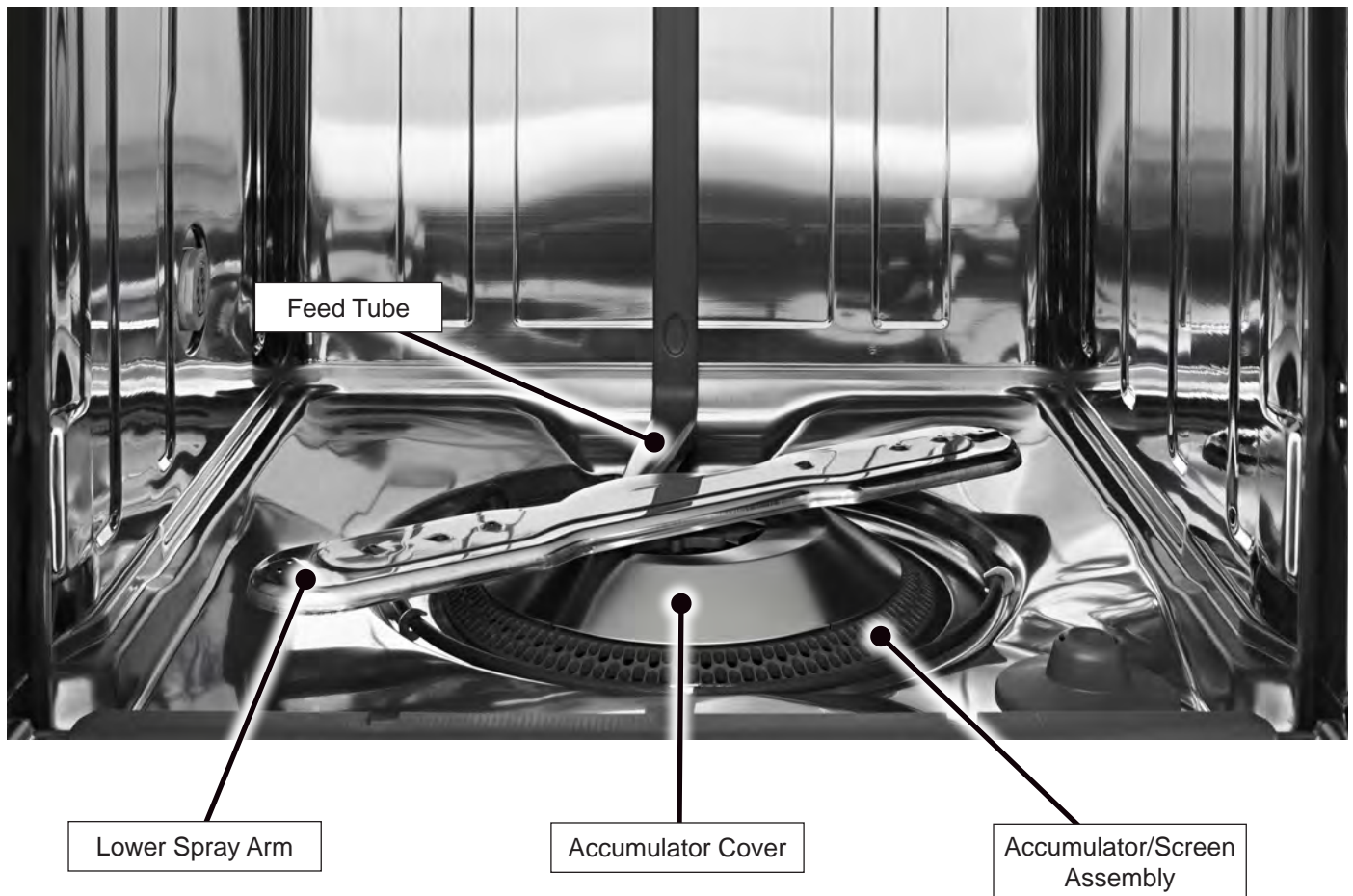

Figure 1

Continued on next page . . .

Removing the Sump Assembly (continued)

Sump Removal:

1. Unplug dishwasher or disconnect power.
2. Perform the procedures on page 4-17, "Remove Drain Pump" prior to performing the following steps.
3. Remove the wire harness from the bracket on the side of the sump and move off to the side, (see Figure 1).

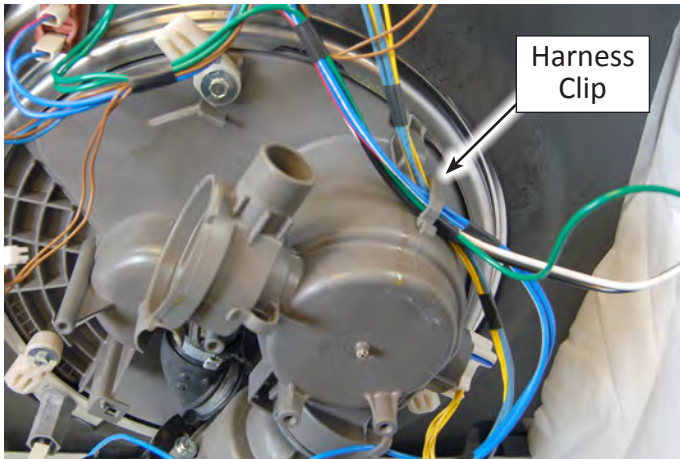

Figure 1

4. Unlock the three tabs securing the motor and sump assembly to the tub, (see Figures 2 and 3).

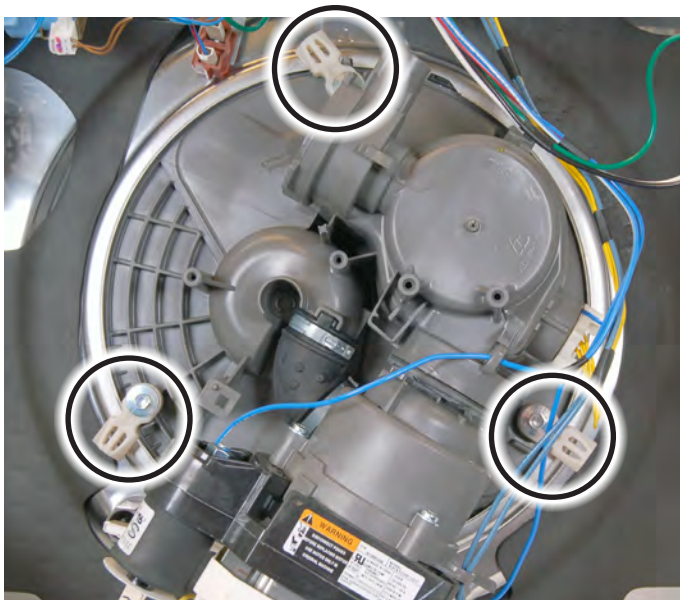

Figure 2 - Locked

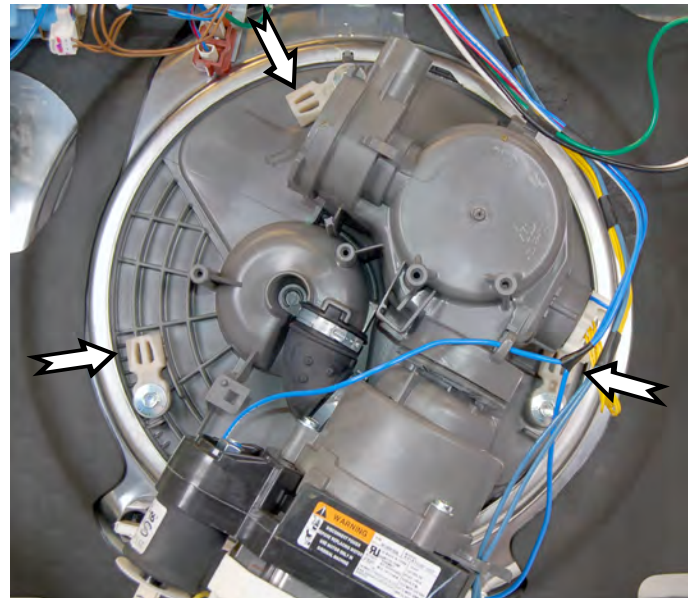

Figure 3 - Unlocked

5. Depress sump release tab located in front of sump. Push upward on sump, from the bottom, to detach from tub. See Figure 4.

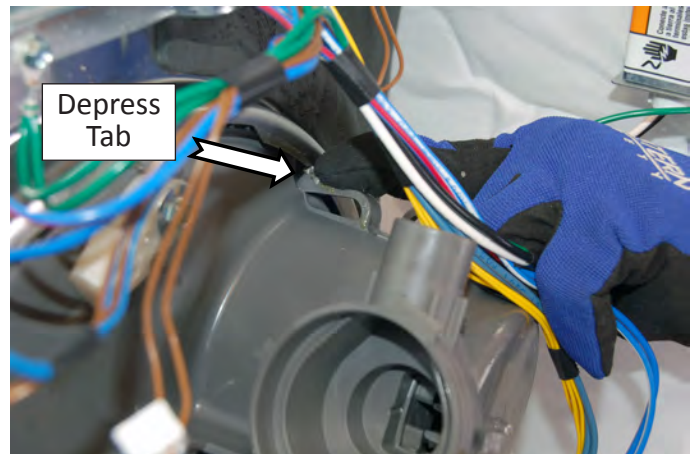

Figure 4

Removing the Sump Assembly (continued)

6. From inside the tub, tilt the sump assembly and lift out far enough to flip sump over. See Figures 5 and 6.



Figure 5

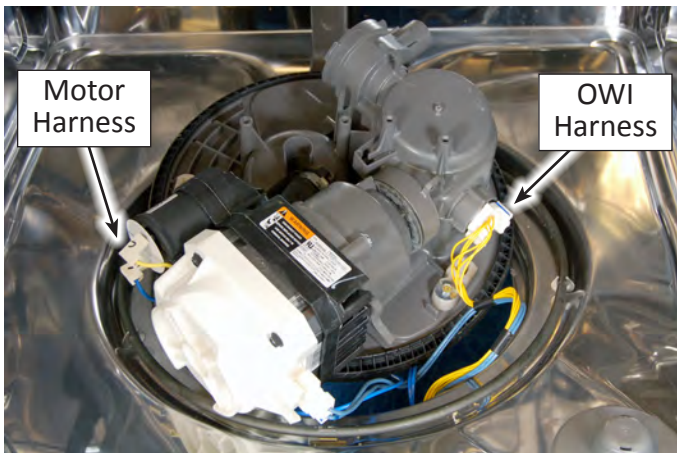

Figure 6

7. With the sump assembly flipped over inside the tub, disconnect the following harness:

Refer to Figure 6 above for harness locations:

- Wash Motor Harness
- OWI Harness (or remove OWI from sump)

8. Remove sump assembly from dishwasher (see Figure 7).



Figure 7 - Sump Assembly

NOTE: When reinstalling the sump assembly, align the tab on the assembly with the slot in the tub. See Figures 8 and 9.



Figure 8



Figure 9

Chopper Motor Assembly Parts

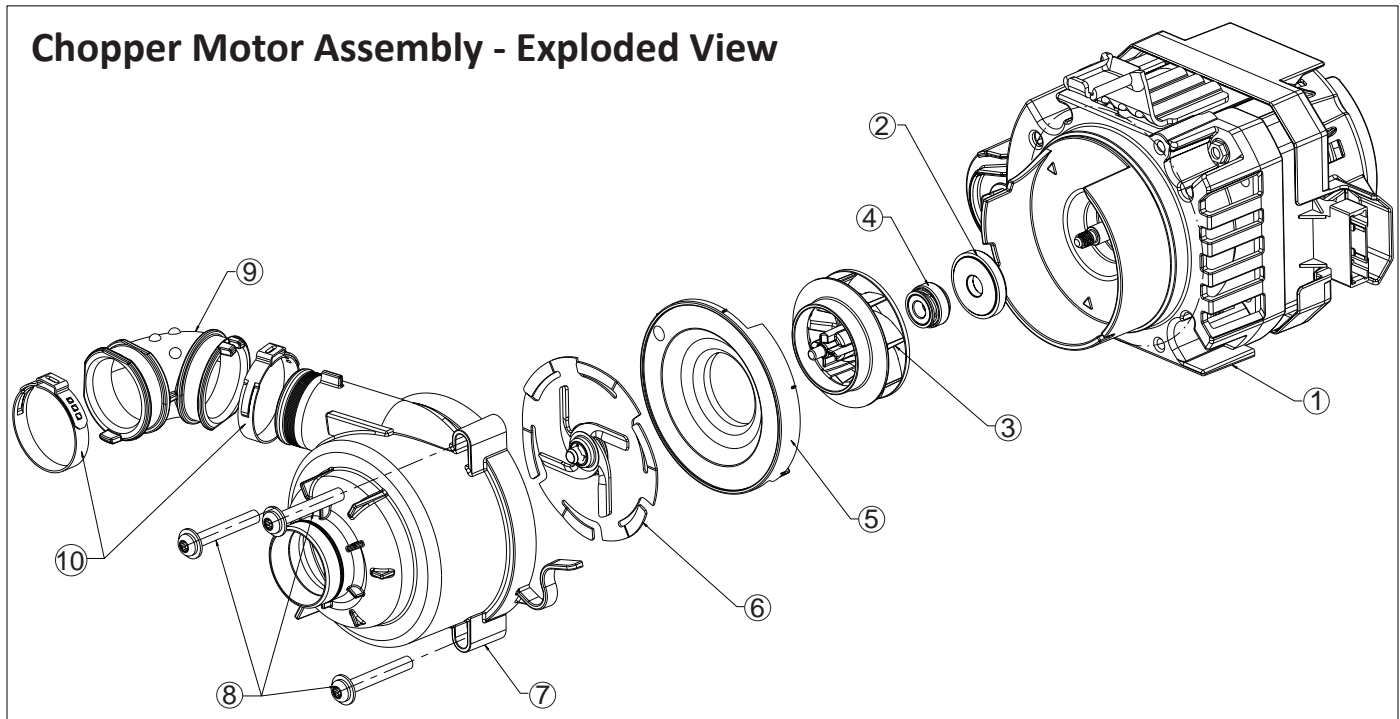

Figure 1 - Exploded View

Chopper Motor Assembly Parts

Number	Description	Qty
1	Motor Assembly	1
2	Face Seal - Seat, Stationary	1
3	Impeller Assembly	1
4	Face Seal - Head, Rotating	1
5	Enclosure - Chopper	1
6	Chopper Assembly - 4 Blade	1
7	Housing-Pump, w/Seal	1
8	Screw 12-16X1.50 PN 6L HL BT SEMS	3
9	Hose - Outlet, Wash Pump	1
10	Stepless Ear Clamp	1
11	Capacitor (shown at right)	1



Figure 2 - Wash Pump Assembly

Removing the Chopper Motor Assembly

WARNING



Electrical Shock Hazard
 Disconnect power before servicing.
 Replace all parts and panels before operating.
 Failure to do so can result in death or electrical shock.

4. Use a screwdriver to gently loosen the seal between the grommet and the sump assembly (see Figure 2).



Figure 2

Removing the Chopper Motor Ass'y

1. Unplug dishwasher or disconnect power.
2. Perform the procedures on page 4-19, "Removing the Sump Assembly" prior to performing the following steps.
3. Remove or loosen clamp from sump side of hose (see Figure 1).



Figure 1



Figure 3

5. Remove Chopper Motor Assembly from sump (see Figure 3).

Removing the Chopper Motor Assembly

Disassemble Chopper Motor Assembly

6. Remove Pump Housing - Remove the three (3) screws securing the pump housing to the motor assembly (see Figure 4).

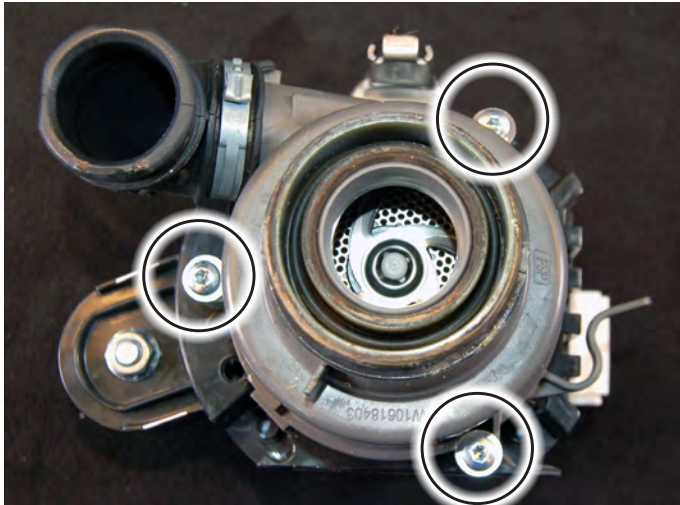

Figure 4

7. Use a screwdriver to separate the pump housing from the motor assembly (see Figure 5).



Figure 5

8. Remove pump housing from motor assembly (see Figure 6).

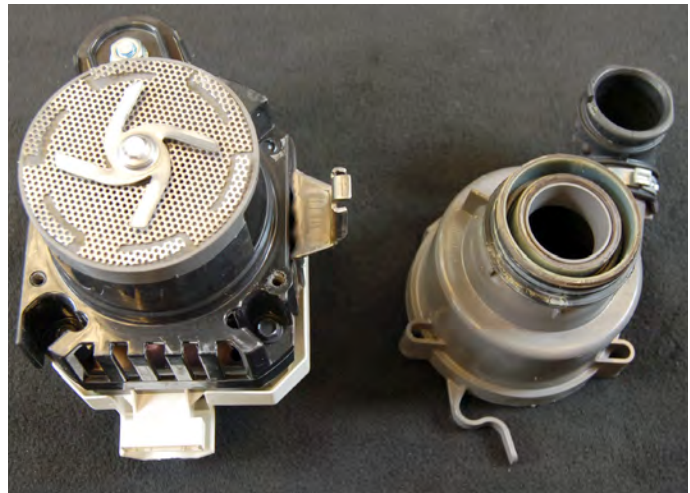

Figure 6

NOTE: The pump housing is keyed to the motor assembly for ease of reassembly.

9. Remove the Chopper Blade from the motor assembly (see Figure 7).

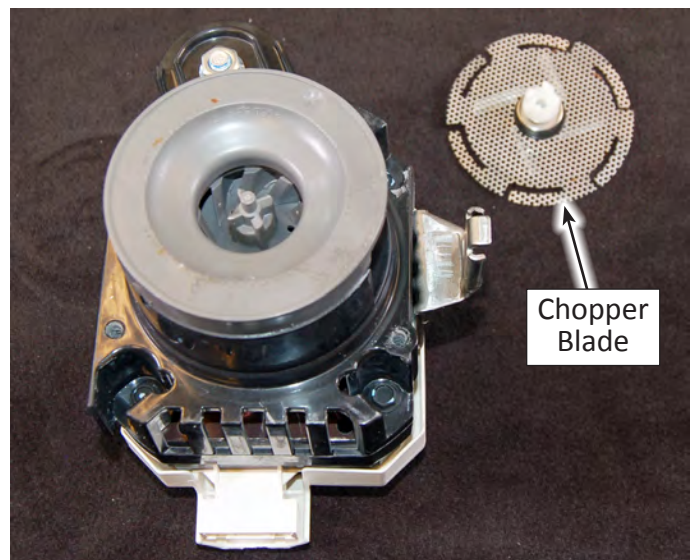

Figure 7

NOTE: The Chopper Blade is keyed to fit on the center shaft of the impeller assembly.

Removing the Chopper Motor Assembly

10. Remove Chopper Enclosure from the motor assembly (see Figure 8).

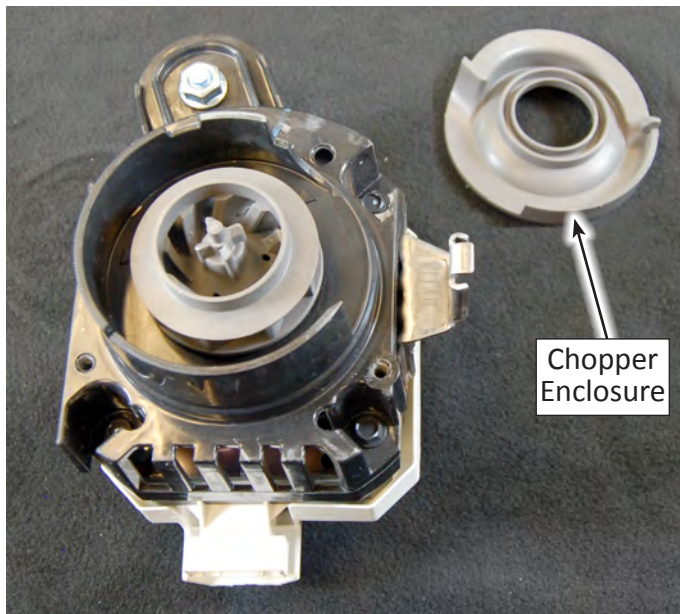

Figure 8

NOTE: The Chopper Enclosure is keyed to fit onto the motor assembly.

11. To remove the impeller; insert a screwdriver into the motor housing vent to prevent the rotor from turning. Firmly grasp the impeller with the other hand and spin it off the motor shaft. See Figures 9 & 10.

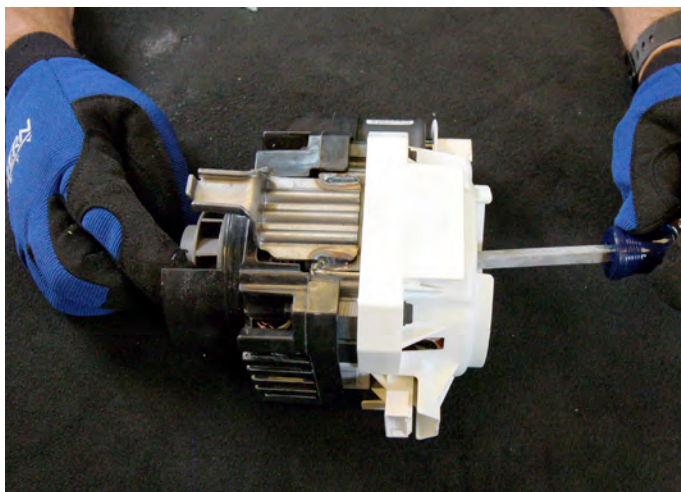

Figure 9

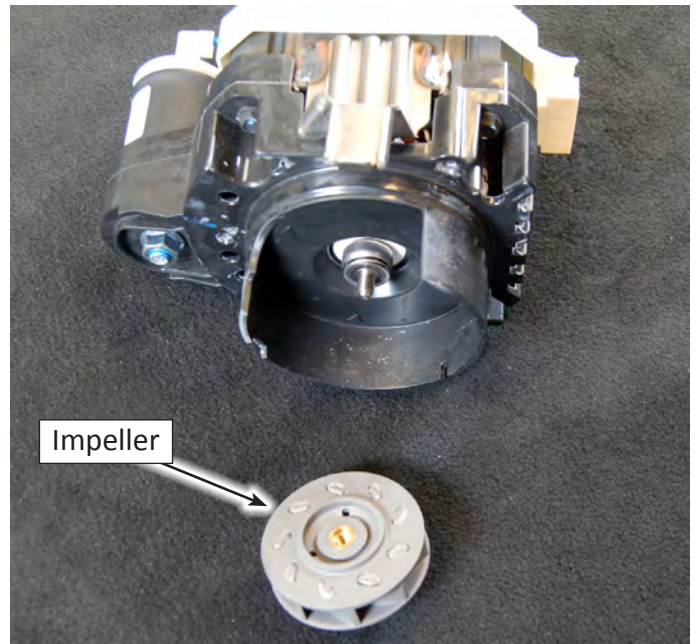

Figure 10

NOTE: The impeller service kit includes the impeller, stationary seat face seal, and rotating seat face seal. See Figure 1 on page 4-22.

Notes

PRODUCT SPECIFICATIONS & WARRANTY INFORMATION SOURCES

IN THE UNITED STATES:

**FOR PRODUCT SPECIFICATIONS AND WARRANTY INFORMATION CALL:
FOR MAYTAG PRODUCTS: 1-800-688-9900**

**FOR TECHNICAL ASSISTANCE WHILE AT THE CUSTOMER'S HOME CALL:
THE TECHNICAL ASSISTANCE LINE: 1-800-832-7174**

**HAVE YOUR STORE NUMBER READY TO IDENTIFY YOU AS AN
AUTHORIZED IN-HOME SERVICE PROFESSIONAL**

**FOR LITERATURE ORDERS (CUSTOMER EXPERIENCE CENTER):
PHONE: 1-800-851-4605**

**FOR TECHNICAL INFORMATION AND SERVICE POINTERS:
www.servicematters.com**

IN CANADA:

**FOR PRODUCT SPECIFICATIONS AND WARRANTY INFORMATION CALL
1-800-807-6777**

**FOR TECHNICAL ASSISTANCE WHILE AT THE CUSTOMER'S HOME CALL:
THE TECHNICAL ASSISTANCE LINE: 1-800-488-4791**

**HAVE YOUR STORE NUMBER READY TO IDENTIFY YOU AS AN
AUTHORIZED IN-HOME SERVICE PROFESSIONAL**

Maytag Dishwashers
4-Blade Stainless Steel Chopper

W11035362